

Kofferträger  
KAWASAKI ZZR 1400

Artikel-Nr.:  
650.2502 00 01 schwarz



Seitenkoffer  
Topcases  
Gepäckträger  
Lock it System  
Softbags  
Aluminiumkoffer  
Lederkoffer  
Schutzbügel  
Hauptständer  
Chopper-Parts  
Quad-Parts  
Accessoires



## Montage

Der Bausatz umfaßt die folgenden Teile:

Stück	Bestellnr.	Bezeichnung	Stück	Bestellnr.	Bezeichnung
1	702.045HB	Kofferträger links	2	150.810	U-Scheiben ø8,4
1	702.046HB	Kofferträger rechts	6	150.809	U-Scheiben ø6,4
1	702.247HB	Versteifungsbügel	6	151.045	Karosserie-Scheibe ø30 x ø10,5 x 2,5
2	702.248HB	Haltelasche vorne unten	4	150.799	selbstsichernde Mutter M6
2	702.249HB	Haltelasche vorne oben	6	151.070	Lock it Systemschrauben (Linsenkopf)
2	702.250HB	Haltelasche hinten oben	6	151.071	Sicherungsscheiben
2	702.251HB	Adapterlasche	6	151.071	Sicherungsscheiben
2	150.812	Aludistanzen ø15 x ø9 x 11,5 mm	1	702.253HB	Bohrschablone
6	150.761	Inbusschrauben M 6 x 16			
2	150.970	Linsenkopfschrauben M 8 x 30			

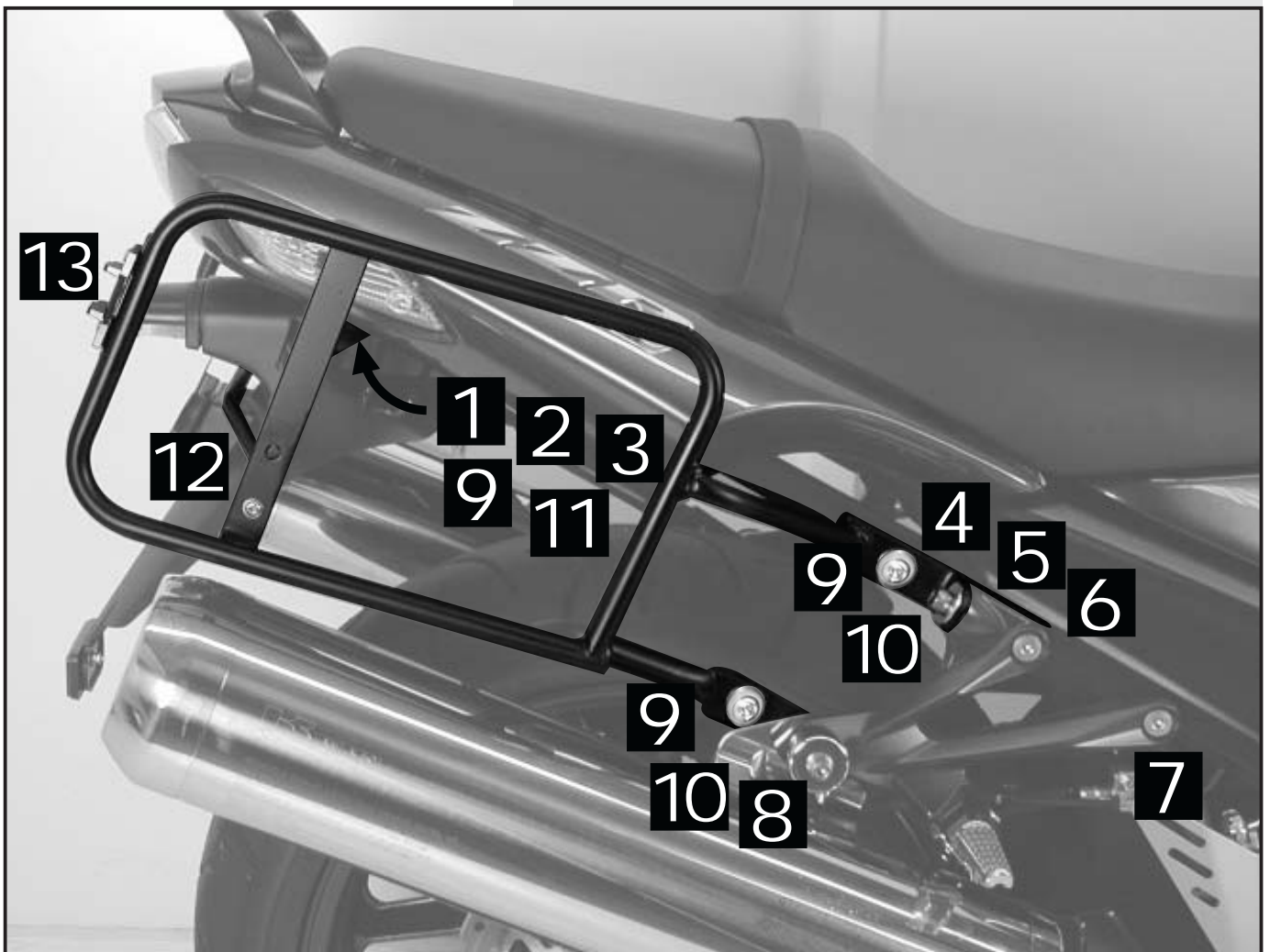

Kofferträger  
KAWASAKI ZZR 1400

Artikel-Nr.:  
650.2502 00 01 schwarz



## Montage

Seitenkoffer  
Topcases  
Gepäckträger  
Lock it System  
Softbags  
Aluminiumkoffer  
Lederkoffer  
Schutzbügel  
Hauptständer  
Chopper-Parts  
Quad-Parts  
Accessoires

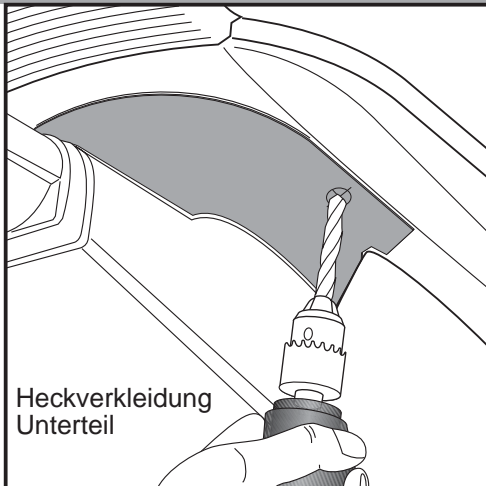

1

Vorbereitende Arbeiten:

Demontieren:

- Sitzbank
- Oberteil Heckverkleidung

Bohrung anbringen zur Montage der Adapterlaschen:

Bohrschablone ausschneiden und auf das Unterteil der Heckverkleidung auflegen. An den vorgezeichneten Punkten eine Bohrungen von jeweils 16 mm anbringen.

**EMPFEHLUNG:**

Die Montage der Kofferträger ist einfacher, wenn bei Montage der Haltelaschen (Bild 3 bis 5) die Schrauben nur leicht angezogen werden, um Korrekturen der Position zu ermöglichen.

Erst nach Montageschritt 9 sollten alle Schrauben fest angezogen werden.

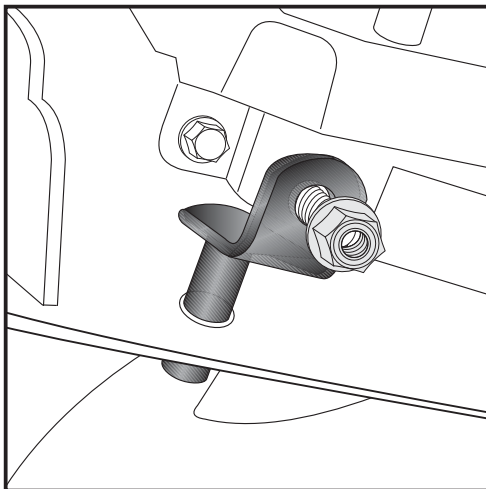

2

Montage der Adapterlaschen:

Die Muttern der Verschraubung der Rahmenunterzüge entfernen. Die Gewinderöhrchen der Adapterlaschen werden von oben durch die angebrachten Bohrungen gesteckt. Die Laschen werden außen an den Rahmenunterzügen mit Originalschrauben und Muttern verschraubt.

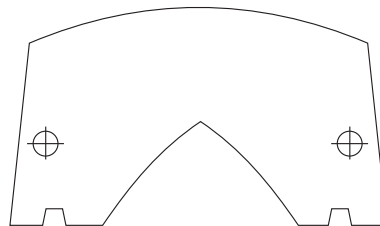

Ø 16 mm

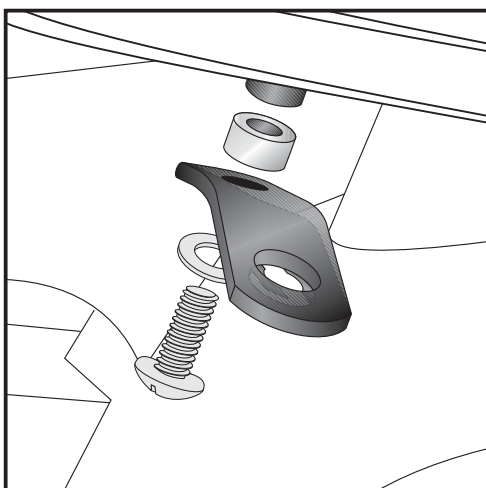

3

Montage der Haltelaschen hinten oben:

In den Gewinden der zuvor montierten Adapterlaschen unter Zwischenfügen der Aludistanzen  $\varnothing 15 \times \varnothing 9 \times 11,5$  mit den Linsenkopfschrauben M8 x 30 und U-Scheiben  $\varnothing 8,4$ .

**HINWEIS:**

Wird gleichzeitig die Gepäckbrücke montiert, entfällt die Aludistanz, stattdessen wird die Lasche der Gepäckbrücke mit der der Brücke beiliegenden Distanz verschraubt.

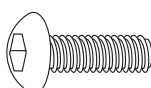

je 2x

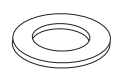

Packende Ideen

2

Kofferträger  
KAWASAKI ZZR 1400

Artikel-Nr.:  
650.2502 00 01 schwarz



## Montage

Seitenkoffer  
Topcases  
Gepäckträger  
Lock it System  
Softbags  
Aluminiumkoffer  
Lederkoffer  
Schutzbügel  
Hauptständer  
Chopper-Parts  
Quad-Parts  
Accessoires

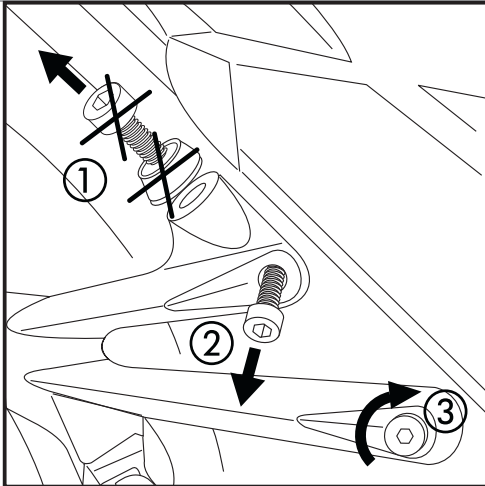

4

Montage der Haltetaschen vorne oben, Vorbereitung:

- ① Die Originalschraube herausnehmen. Diese entfällt, ebenfalls die Aluminium-Aufnahme.
- ② Schrauben Sie die vordere Halte-Schraube des Fußrastenauslegers heraus.
- ③ Lockern Sie die hintere Schraube.

**ACHTUNG: Nicht beide Halte-Schrauben auf einmal lösen, dadurch kann sich der Auspuff absenken.**

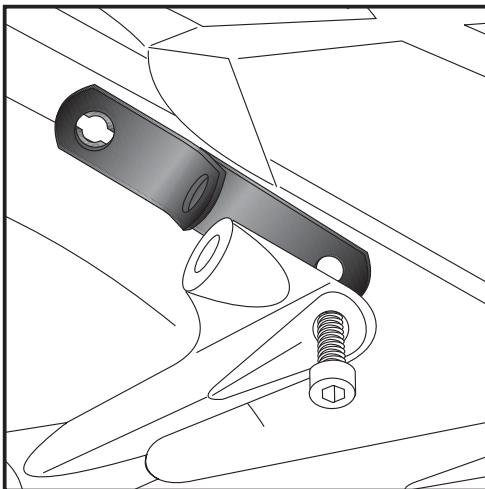

5

Montage der Haltetaschen vorne oben:

Nach Zwischenschieben der Haltetasche die vordere Originalschraube wieder montieren.

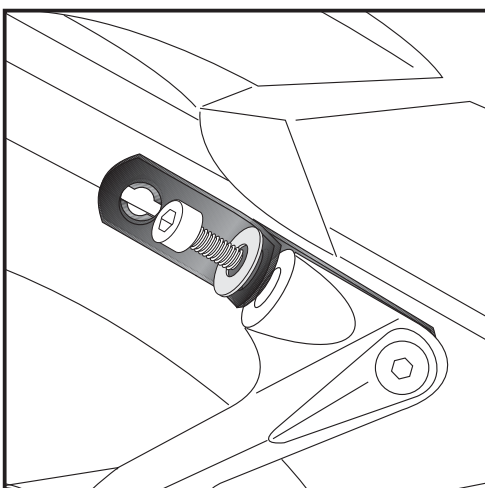

6

Montage der Haltetaschen vorne oben:

In den Gewinden der Soziusfußrastenausleger unter Zwischenfügen der Karosseriescheiben  $\varnothing 30 \times \varnothing 10,5 \times 2,5$  mit den Originalschrauben. Die original Alu-Abdeckungen entfallen.

2x



Kofferträger  
KAWASAKI ZZR 1400

Artikel-Nr.:  
650.2502 00 01 schwarz



## Montage

Seitenkoffer  
Topcases  
Gepäckträger  
Lock it System  
Softbags  
Aluminiumkoffer  
Lederkoffer  
Schutzbügel  
Hauptständer  
Chopper-Parts  
Quad-Parts  
Accessoires

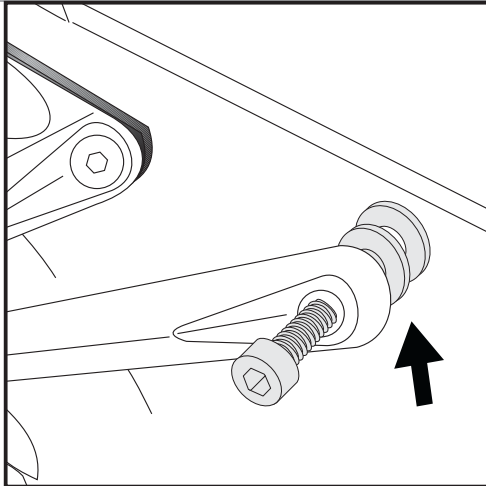

7

Montage der Haltetaschen vorne oben:  
Schrauben Sie die hintere Halte-Schraube des Fußrastenauslegers heraus.  
Nach Zwischenfügen von zwei Karosseriescheiben  
 $\varnothing 30 \times \varnothing 10,5 \times 2,5$  wieder montieren.

4x

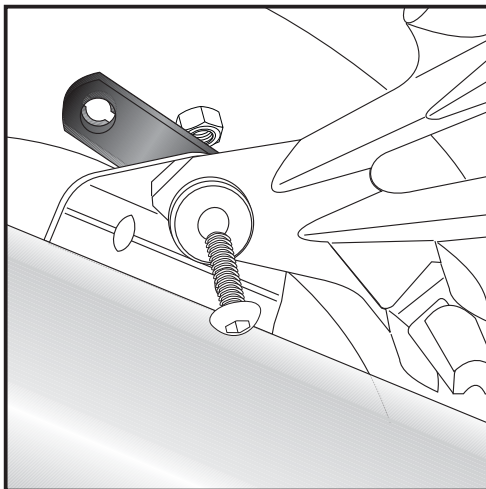
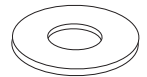

8

Montage der Haltetaschen vorne unten:  
Innen an den Auspufftopfverschraubungen mit den Originalschrauben  
und - Muttern

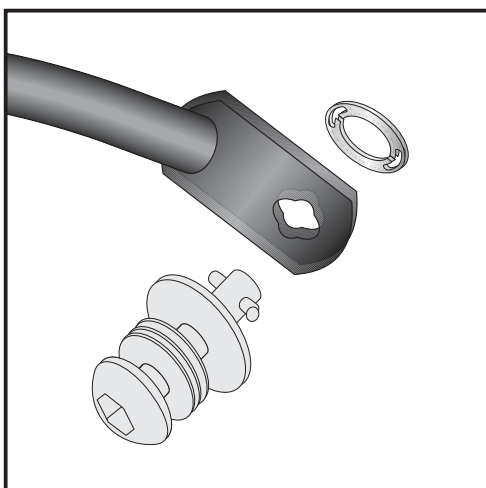

9

Montage der Lock it System-Schrauben:  
An den Kofferträgern links / rechts werden die Lock it System-  
Schrauben an den drei Befestigungslaschen mittels der  
Sicherungsscheibe montiert. Die Scheiben und Lock it System-  
Schrauben verbleiben bei Demontage an den Befestigungspunkten  
der Kofferträger.

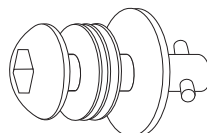

6x



Kofferträger  
KAWASAKI ZZR 1400

Artikel-Nr.:  
650.2502 00 01 schwarz



## Montage

Seitenkoffer  
Topcases  
Gepäckträger  
Lock it System  
Softbags  
Aluminiumkoffer  
Lederkoffer  
Schutzbügel  
Hauptständer  
Chopper-Parts  
Quad-Parts  
Accessoires

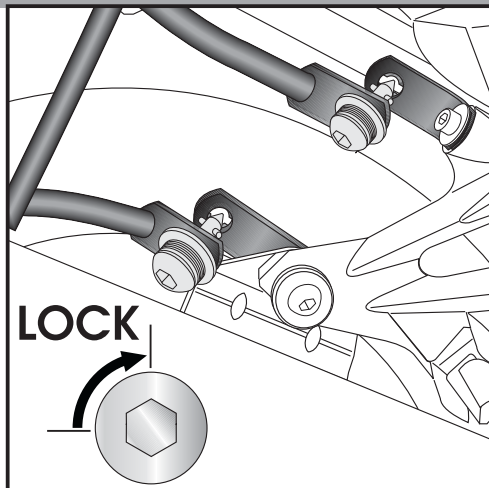

10

Montage der Kofferträger links / rechts:  
Die so vorbereiteten Kofferträger werden an den Haltetaschen mittels der Lock it System-Schrauben befestigt.

### ACHTUNG:

Lock it System-Schrauben nicht überdrehen !  
Langsam drehen (Viertelumdrehung) bis die Schraube fühlbar einrastet und am Anschlag anliegt.

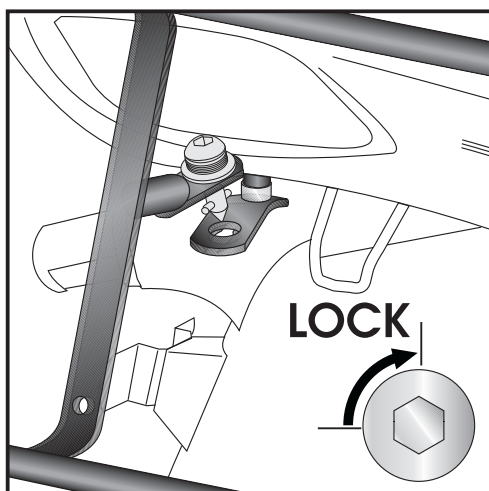

11

Montage der Kofferträger links / rechts:  
Die so vorbereiteten Kofferträger werden an den Haltetaschen mittels der Lock it System-Schrauben befestigt.

### ACHTUNG:

Lock it System-Schrauben nicht überdrehen !  
Langsam drehen (Viertelumdrehung) bis die Schraube fühlbar einrastet und am Anschlag anliegt.

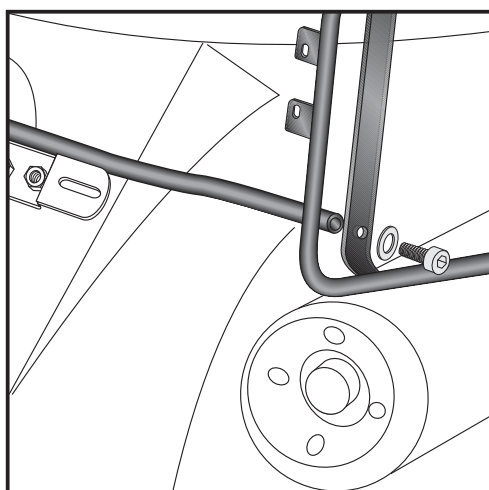

12

Montage des Versteifungsbügels:  
Dieser wird an den Flachstahlbügel der Kofferträger mit den Inbusschrauben M6 x 16 und U-Scheiben ø6,4 verschraubt. Er verläuft zwischen Nummernschildbeleuchtung und Nummernschildhalter auf der Außenseite.

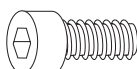

je 2x





Kofferträger  
KAWASAKI ZZR 1400

Artikel-Nr.:  
650.2502 00 01 schwarz



Seitenkoffer  
Topcases  
Gepäckträger  
Lock it System  
Softbags  
Aluminiumkoffer  
Lederkoffer  
Schutzbügel  
Hauptständer  
Chopper-Parts  
Quad-Parts  
Accessoires

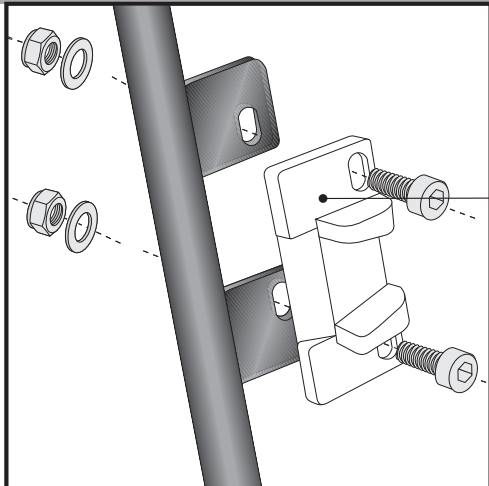

## 13 Hinweise zur Koffermontage

Montage des Metalladapters zum Einhängen des Kofferhalteschlusses

**HINWEIS :**  
die Metalladapter liegen den Koffern bei, nicht diesem Kofferträgerset.

Die notwendigen Schrauben zur Montage der Metalladapter am Kofferträger sind beigelegt (Inbusschrauben M6 x 16, U-Scheiben ø6,4, selbstsichernde Muttern M6).

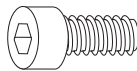

je 4x

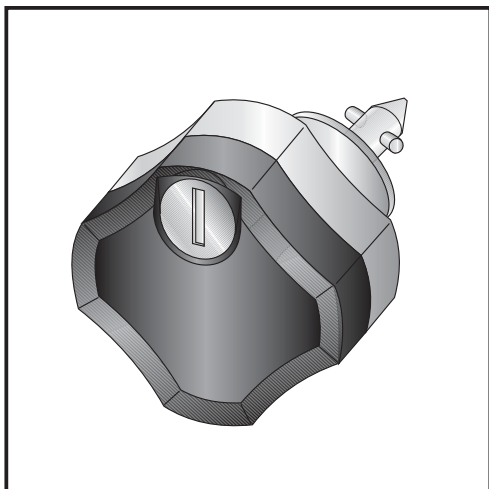

## Diebstahlschutz

Die optional unter der Bestell-Nummer: 151.050 erhältlichen abschließbaren Lock it System-Schrauben stellen einen wirksamen Diebstahlschutz des Kofferträgers dar.

Es wird empfohlen, pro Seite eine normale Lock it System-Schraube durch diese abschließbare Schraube zu ersetzen.

**Nach der Montage alle Verschraubungen auf festen Sitz kontrollieren!  
Bitte beachten Sie unsere beigelegten Serviceinformationen.**

Weiteres Zubehör:  
Gepäckbrücke Art.-Nr.650.2502 01 01 in schwarz -als Ergänzung montierbar



Hepco & Becker GmbH  
An der Steinmauer 6

D-66955 Pirmasens

Tel.: +49 (0)6331 - 1453 - 100  
Fax: +49 (0)6331 - 1453 - 120  
eMail: [vertrieb@hepco-becker.de](mailto:vertrieb@hepco-becker.de)  
[www.hepco-becker.de](http://www.hepco-becker.de)



Kofferträger/side carrier  
KAWASAKI ZZR 1400

Artikel-Nr./Item-No.:  
650.2502 00 01 schwarz/black



Bohrschablone

Drilling - pattern

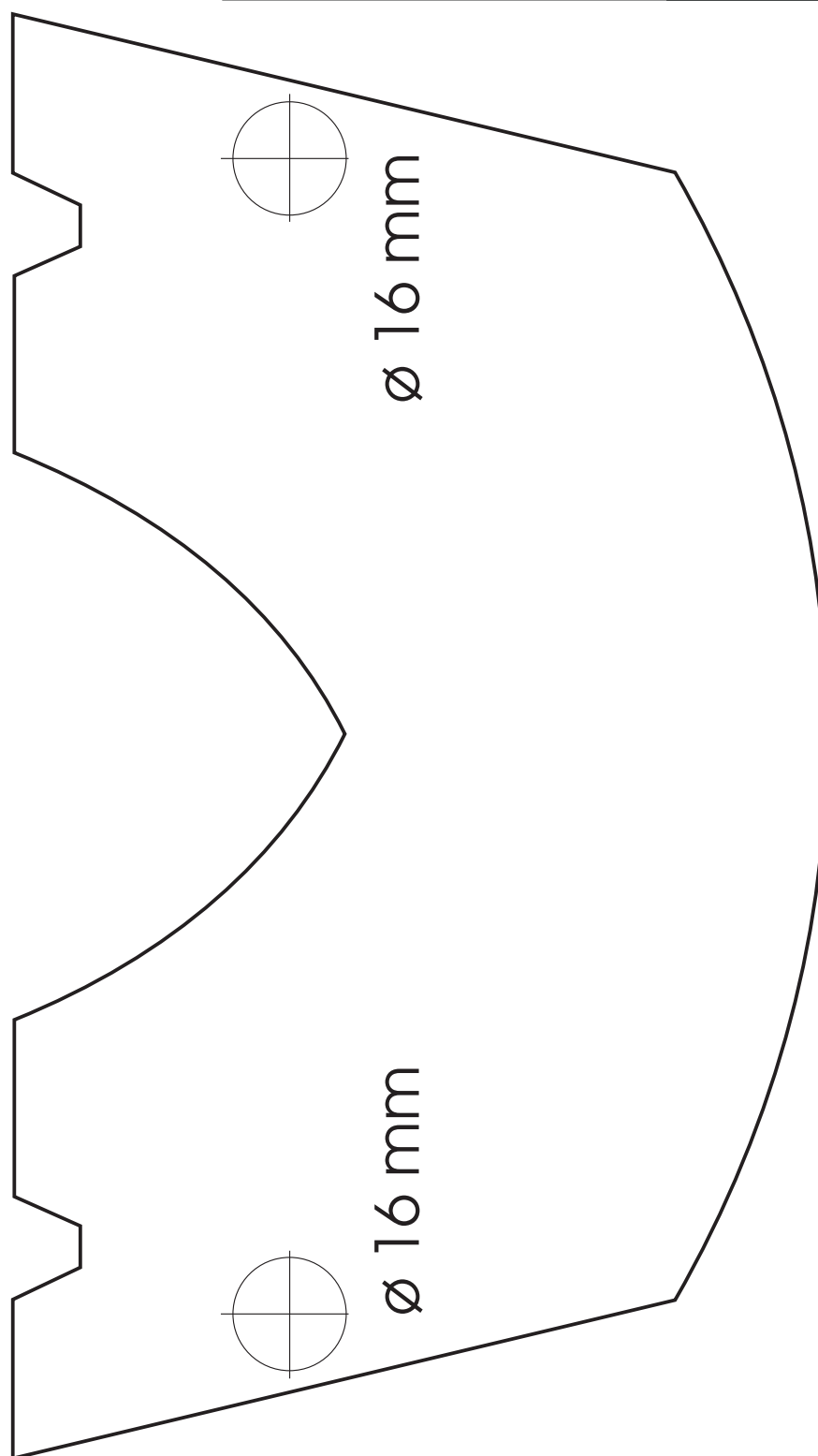



Side carrier  
KAWASAKI ZZR 1400

Item - No.:  
650.2502 00 01 black



## Assembling instructions

Side cases

Top cases

luggage frames

Lock it system

Soffbags

Aluminium luggage

Leather luggage

Protection bars

Center stands

Chopper parts

Quad parts

Accessories



The kit includes the following parts:

Quant	item no.	description	Quant	item no.	description
1	702.045HB	carrier left	2	150.810	washer ø8,4
1	702.046HB	carrier right	6	150.809	washer ø6,4
1	702.247HB	bracing bow	6	151.045	body washer ø30 x ø10,5 x 2,5
2	702.248HB	front mounting strut bottom	4	150.799	self-lock nut M6
2	702.249HB	front mounting strut top	6	151.070	lock it screw
2	702.250HB	rear mounting strut top	6	151.071	lock washer
2	702.251HB	mounting adapter	1	702.253HB	drilling-pattern
2	150.812	alu spacer ø15 x ø9 x 11,5 mm			
6	150.761	allen screw M 6 x 16			
2	150.970	filister head screw M 8 x 30			

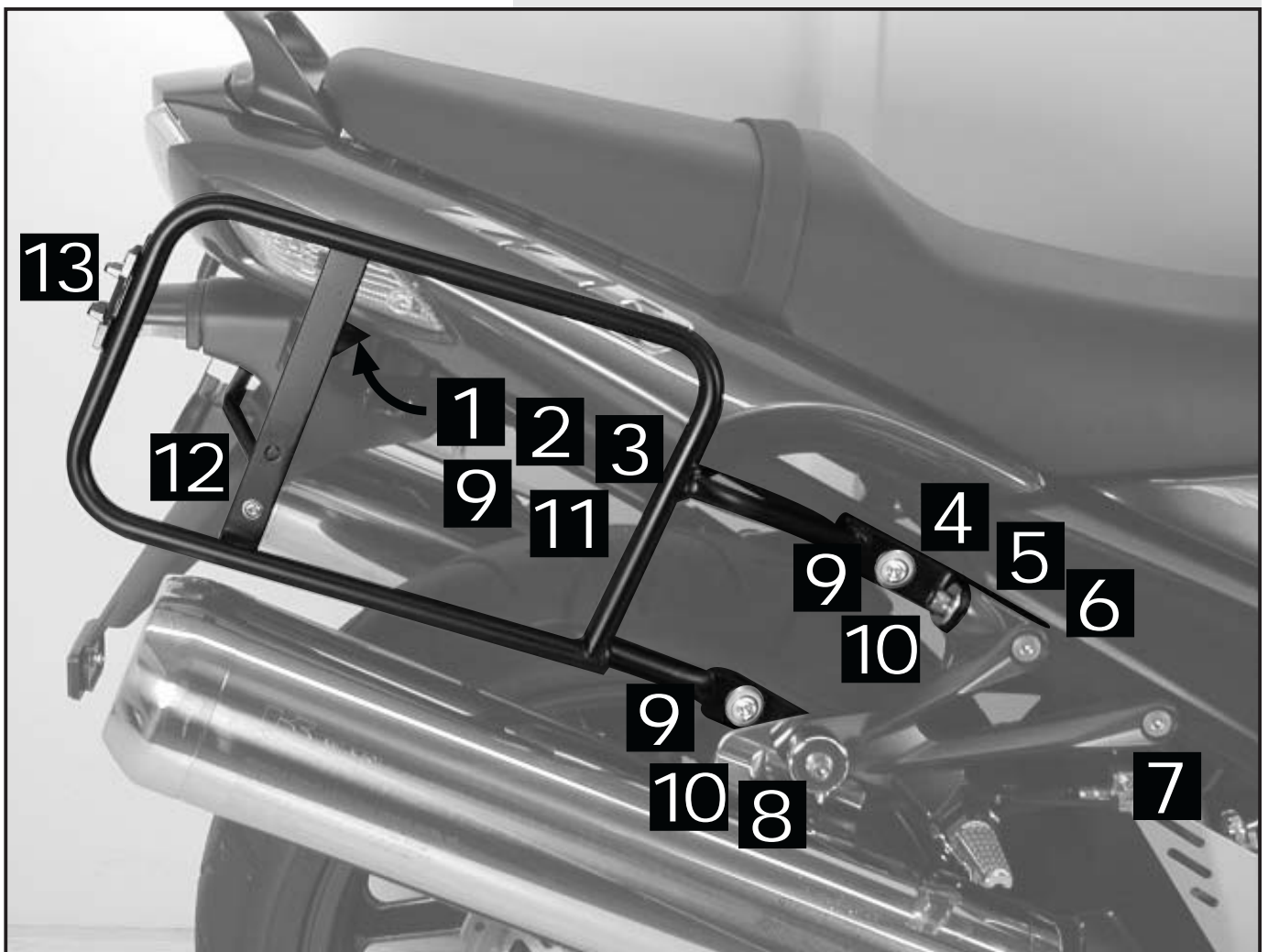

Side carrier  
KAWASAKI ZZR 1400

Item - No.:  
650.2502 00 01 black



## Assembling instructions

Side cases  
Top cases  
luggage frames  
Lock it system  
Softbags  
Aluminium luggage  
Leather luggage  
Protection bars  
Center stands  
Chopper parts  
Quad parts  
Accessories

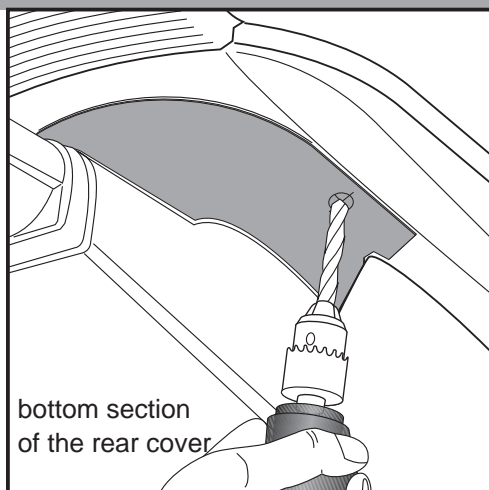

1

Preparing:

Unmount:

- seat
- top section of the rear cover

Drilling holes for fastening of the mounting adapter:

Cut out the drilling-pattern and put it on the bottom section of the rear cover.

Drill at the marked points with 16 mm borer.

Tip:

Fit all parts and screw on not too strong.

After mounting all parts, the screws should be tightened to the torque specified.

This guarantees, that the kit is mounted without tension.

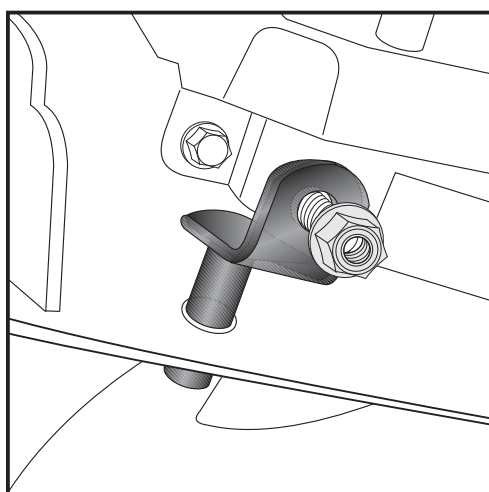

2

Fastening of the mounting adapter:

Unmount nuts in the frame.

Plug the thread-tubes of the mounting adapter through the drilled wholes. Fix them with original screws and nuts.

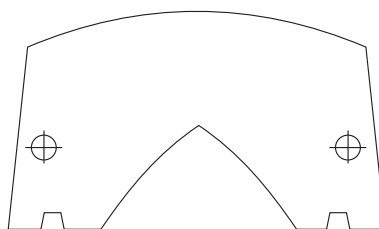

ø 16 mm

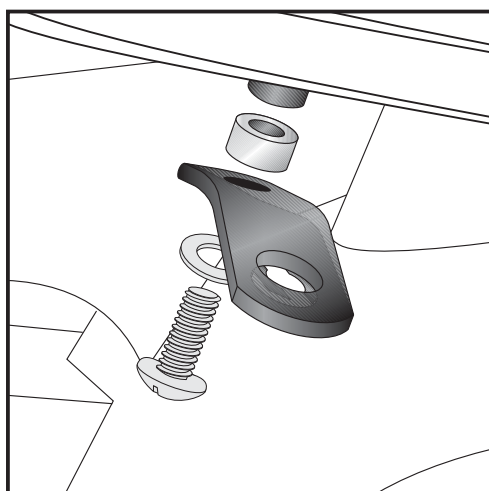

3

Fastening of the rear mounting strut top:

in the thread-tubes of the mounting adapter with filister head screw M8 x 30 and washer ø8,4. Sandwich alu spacer ø15 x ø9 x 11,5.

Notice:

If you mount the side carrier together with the rear rack, the spacer is not needed.

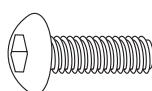

each 2x



Luggage ideas.

2

Side carrier  
KAWASAKI ZZR 1400

Item - No.:  
650.2502 00 01 black



## Assembling instructions

Side cases  
Top cases  
luggage frames  
Lock it system  
Softbags  
Aluminium luggage  
Leather luggage  
Protection bars  
Center stands  
Chopper parts  
Quad parts  
Accessories

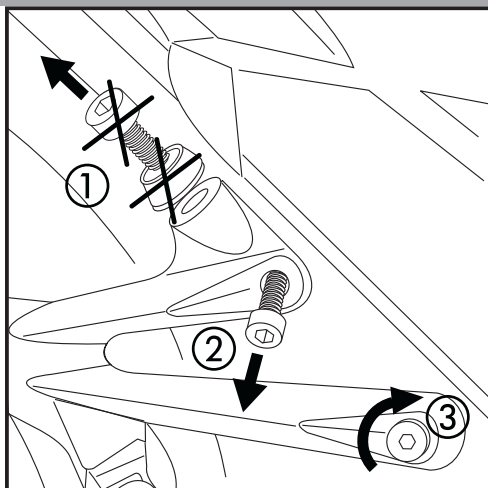

4

Fastening of the front mounting strut top, preparing:

- ① Unmount original screw and spacer. They are not longer needed.
- ② Unmount first screw of the footrest bracket.
- ③ Ease the second screw a bit.

**Notice:** Do not unmount both screws at the same time, otherwise the exhaust can sink down.

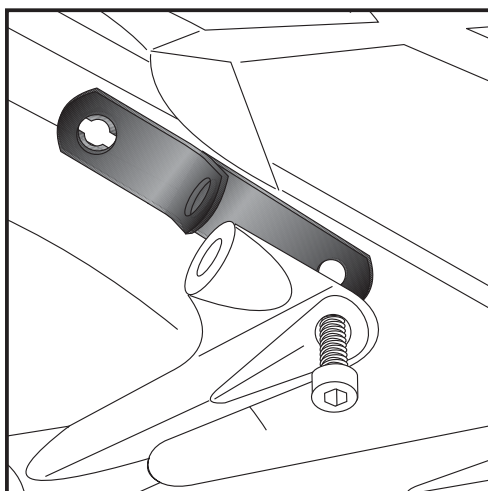

5

Fastening of the front mounting strut top:

Sandwich the front mounting strut top and fix it with original screw.

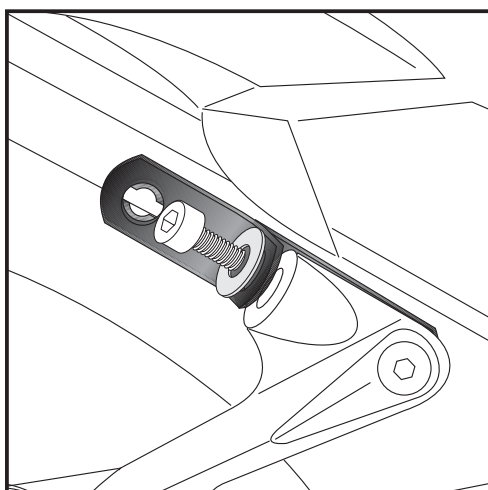

6

Fastening of the front mounting strut top:

Second fixing point: sandwich body washer  $\varnothing 30 \times \varnothing 10,5 \times 2,5$  and use original screw.

2x



Luggage ideas.

Side carrier  
KAWASAKI ZZR 1400

Item - No.:  
650.2502 00 01 black



## Assembling instructions

Side cases  
Top cases  
luggage frames  
Lock it system  
Softbags  
Aluminium luggage  
Leather luggage  
Protection bars  
Center stands  
Chopper parts  
Quad parts  
Accessories

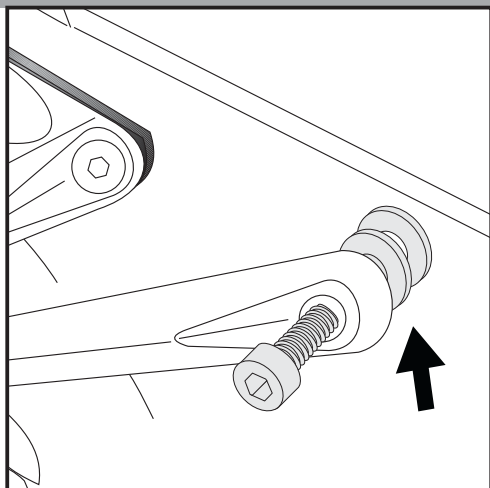

7

Fastening of the front mounting strut top:

Unmount second screw of the footrest bracket completely.  
Sandwich two body washer  $\varnothing 30 \times \varnothing 10,5 \times 2,5$  and fix it again with original screw.

4x

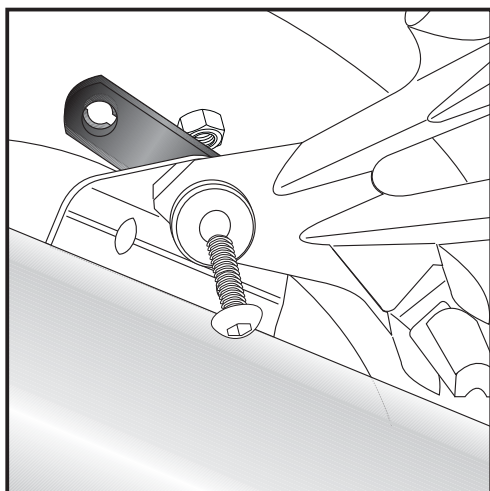

8

Fastening of the front mounting strut bottom:

At the inner side of the exhaust muffler with original screw and nut.

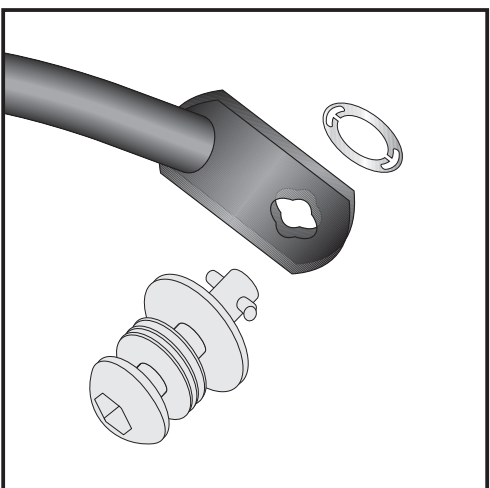

9

Fastening of Lock it screws:

The Lock it screws will be fixed at the carriers left and right with lock washers.

You have to do it only once - the screws and lock washers remain at the carriers.

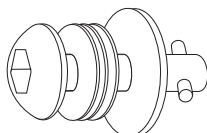

6x



Luggage ideas.

Side carrier  
KAWASAKI ZZR 1400

Item - No.:  
650.2502 00 01 black



## Assembling instructions

Side cases  
Top cases  
luggage frames  
Lock it system  
Softbags  
Aluminium luggage  
Leather luggage  
Protection bars  
Center stands  
Chopper parts  
Quad parts  
Accessories

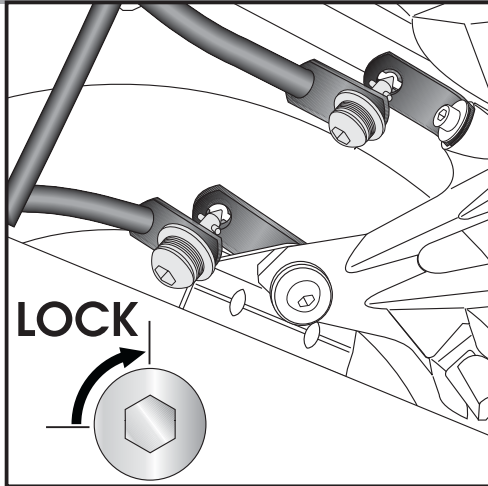

10

Fastening of carrier left + right:

The carriers will now be fixed to the adapter with Lock it -screws

**Attention !**

Don't overturn the Lock it screw !

Rotate slowly one quarter of a turn until screw engages.

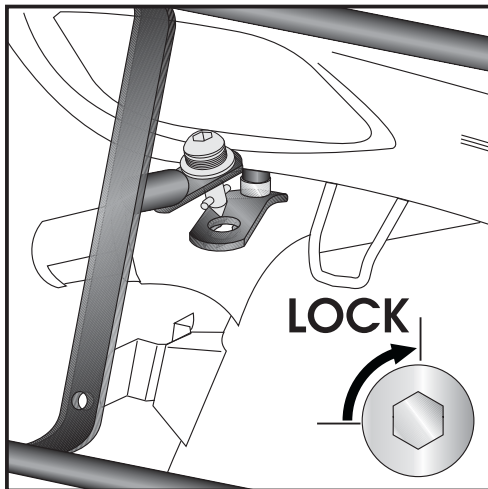

11

Fastening of carrier left + right:

The carriers will now be fixed to the adapter with Lock it -screws

**Attention !**

Don't overturn the Lock it screw !

Rotate slowly one quarter of a turn until screw engages.

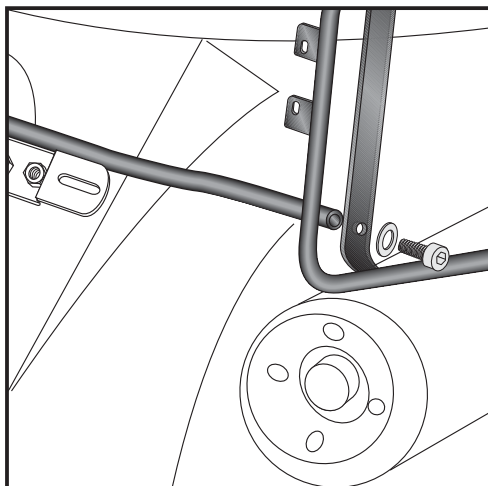

12

Fastening of the bracing bow:

Outside the fender above number plate holder with hexagon bolt M 6 x 16 and washer  $\varnothing 6,4$ .

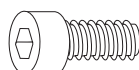

each 2x



Luggage ideas.

Side carrier  
KAWASAKI ZZR 1400

Item - No.:  
650.2502 00 01 black



## Assembling instructions

Side cases  
Top cases  
luggage frames  
Lock it system  
Softbags  
Aluminium luggage  
Leather luggage  
Protection bars  
Center stands  
Chopper parts  
Quad parts  
Accessories

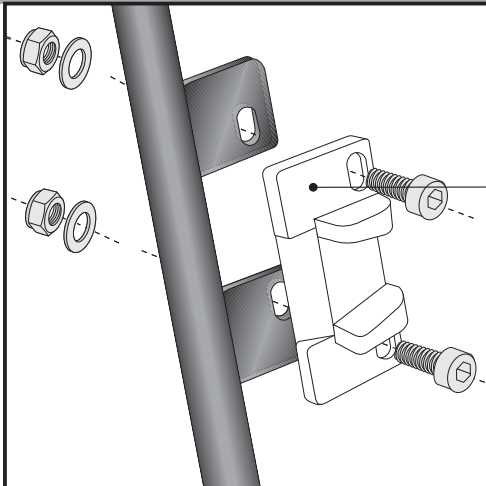

## Hint: assembling side cases

Fastening of adapter to hook in the fixing lock

Hint :

The adapters are enclosed with the side cases.  
They are not included in the side carrier set.

The necessary screws for mounting the metal adapter on the carrier are part of this set.

(Filister headscrew M6 x 16, washer ø6,4 and self lock nut M6).

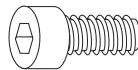

each 4x

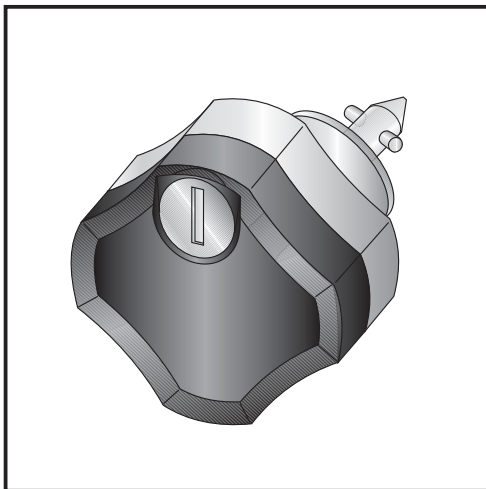

## Anti-theft-device

Sold separately - item-no: 151.050

It is recommended to use one on each side of the side-carrier,  
instead of the ordinary lock-it screw, for theft protection.

**Control all screw connections after the assembling for tightness!**  
Please notice our enclosed service information.

Also available:  
650.2502 01 01 Rear rack black



Hepco & Becker GmbH  
An der Steinmauer 6

D-66955 Pirmasens

Tel.: +49 (0)6331 - 1453 - 100

Fax: +49 (0)6331 - 1453 - 120

eMail: [vertrieb@hepco-becker.de](mailto:vertrieb@hepco-becker.de)

[www.hepco-becker.de](http://www.hepco-becker.de)