

SR357 - KR357

PORTAVALIGIA SPECIFICO - SPECIFIC CASE HOLDER
 PORTE-VAUSE SPECIFIQUE - SPEZIFISCHER KOFFER-TRÄGER
 PORTA-EQUIPALE ESPECIFICO

YAMAHA FJR1300 2006

ISTRUZIONI DI MONTAGGIO - MOUNTING INSTRUCTIONS
 INSTRUCTIONS DE MONTAGE - BAUANLEITUNG - INSTRUCCIONES DE MONTAJE

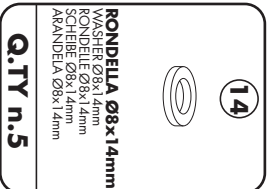
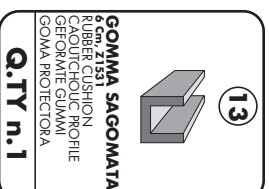
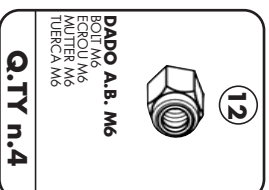
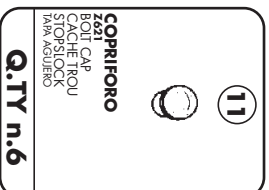
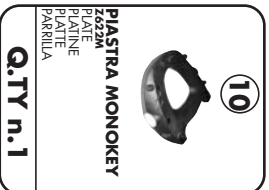
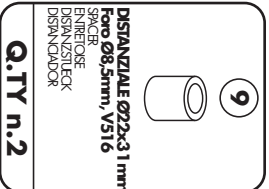
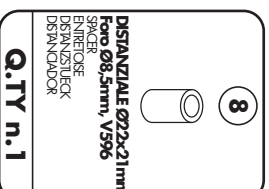
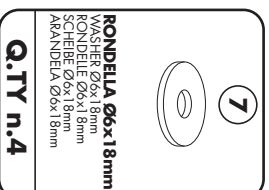
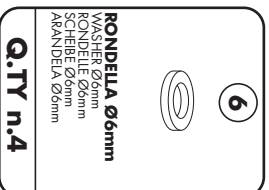
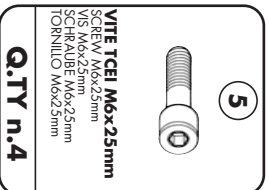
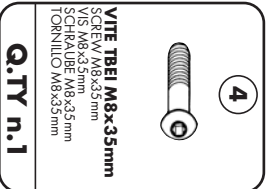
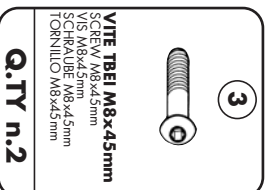
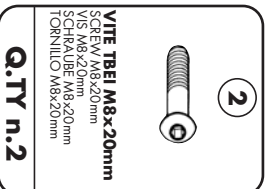
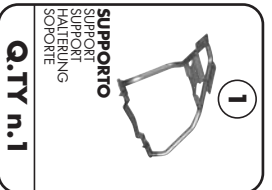

ATTENZIONE
 PESO MASSIMO SOPPORTABILE DAL PORTAPACCO
 10Kg.

WARNING
 MAX. LOADING OF THE CARRIER 10Kg. (21lbs)

ATTENTION
 CHARGE MAXIMALE 10Kg.

ACHTUNG
 MAXIMALE BELASTUNG DES TRÄGERS 10Kg.

¡ATENCIÓN!
 CARGA MÁXIMA AUTORIZADA 10Kg.

A

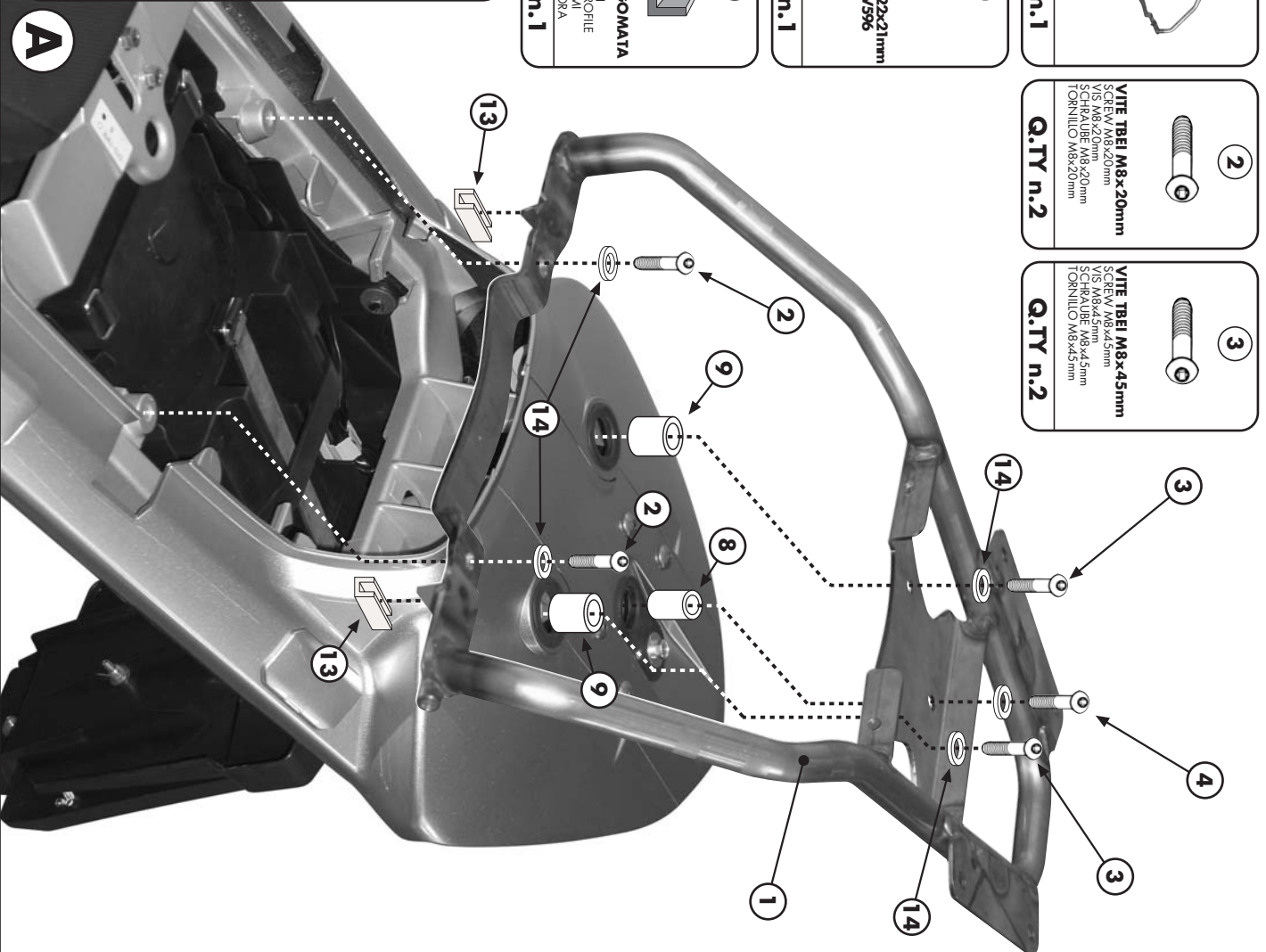

PORTAVALLIGIA SPECIFICO - SPECIFIC CASE HOLDER
PORTE-VALISE SPECIFIQUE - SPEZIFISCHER KOFFER-TRÄGER
PORTA-EQUIPAGE ESPECIFICO

YAMAHA FJR1300 2006

ISTRUZIONI DI MONTAGGIO - MOUNTING INSTRUCTIONS
INSTRUCTIONS DE MONTAGE - BAUANLEITUNG - INSTRUCCIONES DE MONTAJE

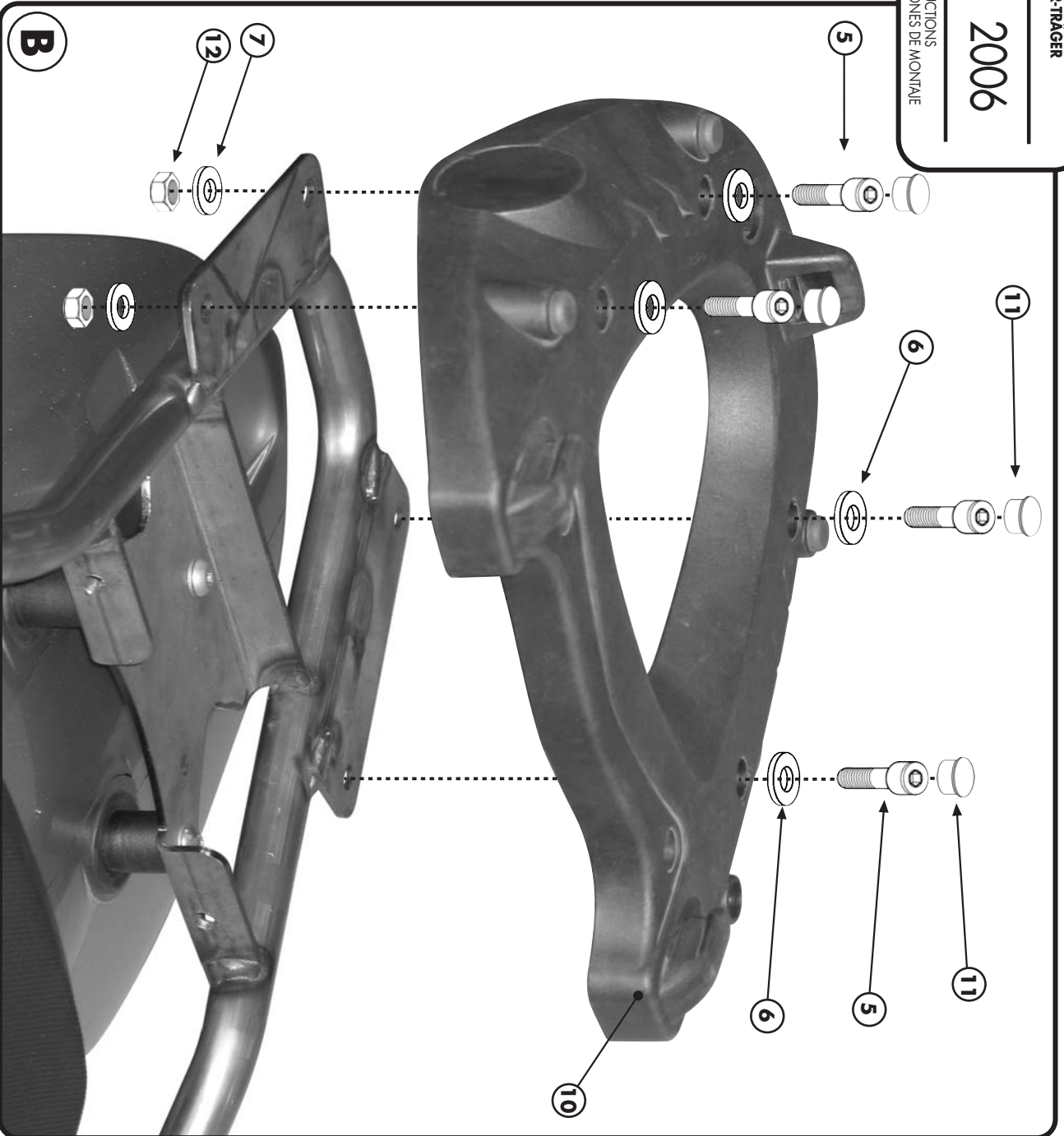

PORTAVALLIGIA SPECIFICO - SPECIFIC CASE HOLDER
 PORTE-VALISE SPECIFIQUE - SPEZIELISCHER KOFFER-TRÄGER
 PORTA-EQUIPALE ESPECIFICO

YAMAHA FJR1300 2006

ISTRUZIONI DI MONTAGGIO - MOUNTING INSTRUCTIONS
 INSTRUCTIONS DE MONTAGE - BAUANLEITUNG - INSTRUCCIONES DE MONTAJE

I ISTRUZIONI DI MONTAGGIO

1. SMONTARE IL MANIGLIONE ORIGINALE.
2. MONTARE IL PORTAVALLIGIA POSTERIORE COME INDICATO IN FOTOGRAFIA A E B. FARE ATTENZIONE AL POSIZIONAMENTO DELLE PROTEZIONI IN GOMMA N°13. COME INDICATO IN FOTOGRAFIA A.
3. ULTIMARE IL MONTAGGIO VERIFICANDO CHE TUTTE LE VITI SIANO SERRATE BENE E CHE IL TAPPO ANTIFURTO ED I GOMMINI SIANO MONTATI CORRETTAMENTE SULLA PIASTRA.

GB MOUNTING INSTRUCTIONS

1. REMOVE THE ORIGINAL GRAB RAILS.
2. MOUNT THE TOP-CASE CARRIER AS SHOWN IN PICTURES A AND B. PAYING PARTICULAR ATTENTION IN ORDER TO PLACE THE RUBBER PROTECTION N°13 CORRECTLY AS SHOWN IN PICTURE A.
3. LASTLY CHECK THAT ALL SCREWS HAVE BEEN TIGHTENED AND THAT THE RUBBERS AND THE ANTI-THEFT CAP HAVE BEEN CORRECTLY POSITIONED ON THE PLATE.

F ISTRUCTIONS DE MONTAGE

1. DEMONTER LA POIGNEE D'ORIGINE :
2. MONTER LE SUPPORT TOP CASE COMME INDIQUE EN PHOTOS A ET B : FAIRE ATTENTION AU POSITIONNEMENT DES PROTECTIONS EN GOMME N°13 COMME MONTRE EN PHOTO A :
3. TERMINER LE MONTAGE EN CONTROLANT LE BON SERRAGE DE TOUTES LES VIS AINSI QUE LA MISE EN PLACE DU BOUCHON ANTIVOL ET DES SILENT BLOCS SUR LA PLATINE.

D BAUANLEITUNG

1. ENTFERNEN SIE DEN ORIGINAL HANDGRIFF.
2. MONTIEREN SIE DEN KOFFERTRÄGER WIE IN DEN BILDERN A UND B BESCHRIEBEN. POSITIONIEREN SIE DIE GUMMISCHUTZE NR. 13 WIE IM BILD A BESCHRIEBEN.
3. ZULETZT ÜBERPRÜFEN SIE, DASS ALLE SCHRAUBEN FESTGEZOGEN WURDEN UND DASS DIE GUMMISTOPFSEL SOWIE DIE DIEBSTAHLSICHERUNG AUF DER PLATTE KORREKT POSITIONIERT WURDEN.

ES

INSTRUCCIONES DE MONTAJE

1. DESMONTAR EL ASA ORIGINAL
2. MONTAR EL PORTAEQUIPALES POSTERIOR TAL Y COMO SE INDICA EN LA FOTOGRAFÍA A Y B. PRESTAR ESPECIAL ATENCIÓN EN EL POSICIONAMIENTO DE LAS GOMAS PROTECTORAS (Nº13), TAL Y COMO SE MUESTRA EN LA FOTOGRAFÍA A.
3. ULTIMAR EL MONTAJE VERIFICANDO QUE TODOS LOS TORNILLOS ESTAN BIEN APRETADOS Y QUE EL TAPON ANTIRROBO Y LAS GOMAS ESTAN MONTADAS CORRECTAMENTE EN LA PARRILLA.