



YOSHIMURA

RESEARCH&DEVELOPMENT OF AMERICA, INC.

5420 DANIELS STREET STE A, CHINO CA 91710 · (800) 634-9166 · (909) 628-4722 · FAX (909) 591-2198

WWW.YOSHIMURA-RD.COM

SIGNATURE SERIES

ENDURO SERIES

Qualified Manufacturer Declared "Replacement Part"

KTM

2016~2018 450 SX-F

Husqvarna

2016~2018 FC450

KTM

2017~2019 500 EXC-F

2017~2018 450 XC-F

Husqvarna

2017~2018 FX 450

264612D321 (AL/CF)

Stainless Steel RS4 Slip-On



Signature Series systems are:

- CARB/EPA tail-pipe emissions compliant.
- Marked with appropriate EPA noise labels.
- Independent laboratory tested for EPA new vehicle noise compliance.



Enduro Series systems are:

- Equipped with USFS-approved spark arrestor.
- CARB/EPA tail-pipe emissions compliant.
- All applications are marked with appropriate EPA noise labels.
- Have not been tested for EPA new vehicle noise compliance.



CAUTION: The muffler packing on this system MUST be replaced every 6-8 hours of use, or after each moto. Failure to follow recommended muffler re-packing interval can cause muffler damage and may void the warranty.



NOTE: IN THE STATE OF CALIFORNIA, IT IS ILLEGAL TO MODIFY THE EMISSION CONTROL SYSTEM, WHICH INCLUDES THE CARBURETORS OF ANY VEHICLE.

Assembly Diagram

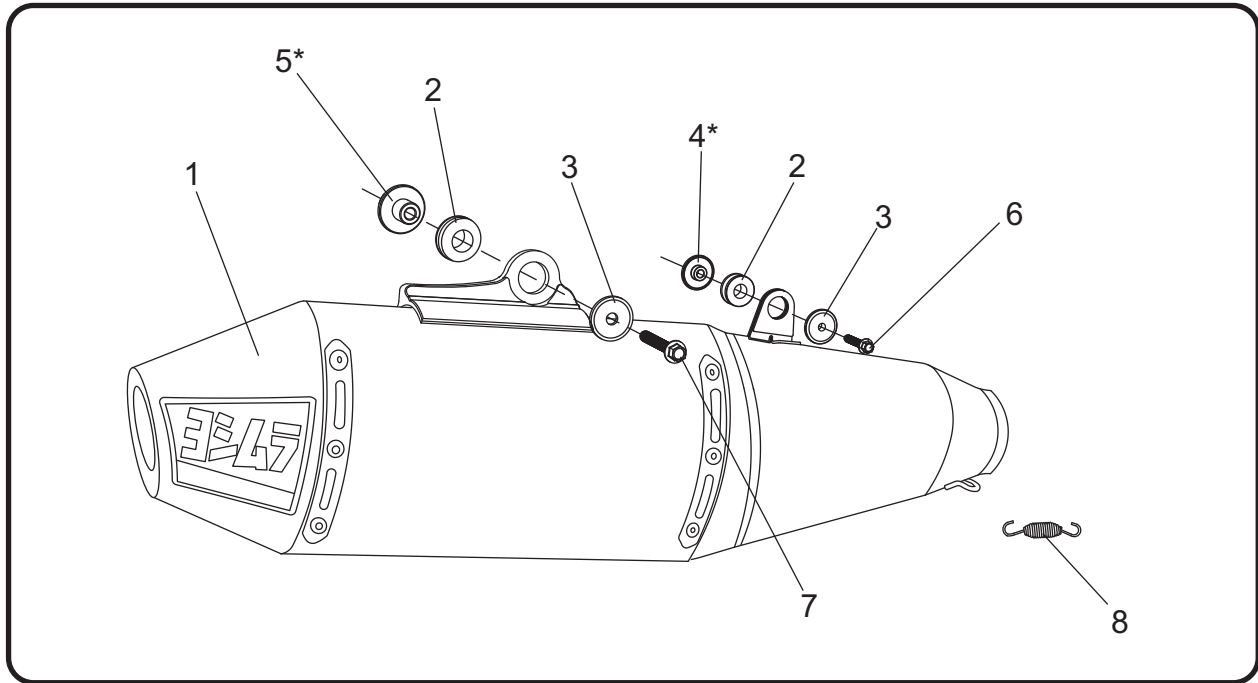

No.	Item	Description	Qty.
1	264612D320-RMA	Yoshimura Muffler Assembly	1
2	Z1023	Rubber Grommet	2
3	ALS-046	Aluminum Spacer	2
4*	ALS-054	Aluminum Spacer for Husqvarna	1
	ALS-057	Aluminum Spacer for KTM	1
5*	ALS-047	Aluminum Spacer for Husqvarna	1
	ALS-056	Aluminum Spacer for KTM	1
6	M6X35H	6mm x 35mm Flanged Hex Head Bolt	1
7	M6X45H ¹	6mm x 45mm Flanged Hex Head Bolt	1
	M6X50H ²	6mm x 50mm Flanged Hex Head Bolt	1
8	RACE-SPS-1	Medium Exhaust Spring	1
**	INS-U-3	Low Volume Sound Insert (Installed)	1
**	SA-04-K	Spark Arrester Kit	1
**	ST-200	Spring Puller Tool	1
**	347PLUG	Wash Plug	1
**	17029	Sticker Sheet	1
OPTIONAL REPLACEMENT PARTS			
	INS-23-K	Low Volume Sound Insert Kit	
	REPACK-RS4-PK12	Re-pack Kit	

** Not shown on diagram.

¹ M6X45H used on KTM 450SX-F.

² M6X50H used on Husqvarna FC450.

CAUTION: Exhaust system can be extremely hot. Let motorcycle cool down before beginning installation. Always wear hand and eye protection and take precautionary measures to avoid injury.

WARNING: Always properly support vehicle with a stand and/or lift when servicing or performing any work. Unstable vehicles may present dangerous conditions and may cause property damage and/or personal injury.

NOTE: Read through all instructions before beginning installation.

Removal

1. Remove the stock exhaust spring between the muffler and header.
2. While securely supporting the stock muffler, remove the two muffler mount bolts and carefully remove the stock muffler by sliding toward the rear.

Installation

1. Install (No. 2) Z1023, rubber grommet into muffler resonator bracket.

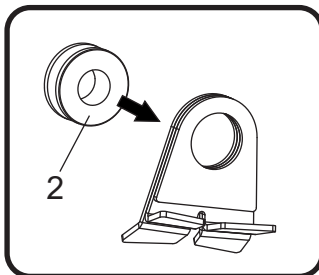

2. Install (No. 3) ALS-046, aluminum spacer in the front side of (No. 2) Z1023, rubber grommet and install (No. 4) ALS-054 for Husqvarna OR ALS-057, aluminum spacer in the back side of (No. 2) Z1023, rubber grommet as shown.

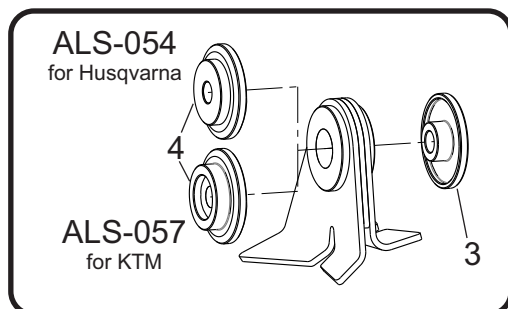

3. Install (No. 2) Z1023, rubber grommet into muffler bracket.

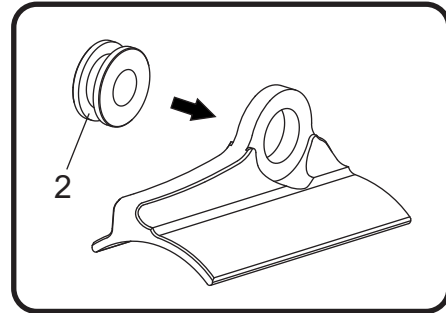

4. Install (No. 5) ALS-047 for Husqvarna OR ALS-056 for KTM, aluminum spacer in the backside of (No. 2) Z1023, rubber grommet and install (No. 3) ALS-046, aluminum spacer in the frontside as shown below.

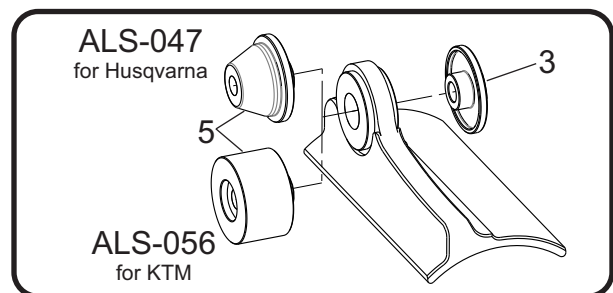

5. Install (No. 1) muffler, onto the stock header outlet. Align muffler bracket and muffler resonator bracket to subframe and secure using (No. 6,7) 6mm bolts as shown in the assembly diagram.

Note: It is recommended to trim the tab on the bottom right airbox cover near the header outlet.



6. Torque muffler mount bolts to factory specification.

7. Install (No. 8) *RACE-SPS-1*, medium exhaust spring between Yoshimura muffler and stock header.
8. Before starting vehicle, check for proper clearance between new exhaust system and rear suspension (i.e. tire, swingarm, brakes, rear shock, and etc.) If any problem is found, please carefully follow through the installation steps again. If problem still persists, please call Yoshimura Tech Department at (800) 634-9166 / in CA (909) 628-4722.
9. It is recommended that the muffler and tailpipe be wiped down with rubbing alcohol to remove oil and fingerprints. This will help prevent tarnishing of the finish after the exhaust is heated up.

Note: After starting motorcycle, it is normal for new exhaust system and muffler to emit smoke until oil residue burns off.

IMPORTANT NOTE

Enduro Series Applications:

The supplied spark arrestor and USFS decal MUST be installed on muffler before operating vehicle in order for legal use on public lands.

Spark arrestor is USFS approved and 96dB or lower compliant.

License plate and turn signals must be relocated for EXC-F models.