



YOSHIMURA

RESEARCH&DEVELOPMENT OF AMERICA, INC.

5420 DANIELS STREET STE A, CHINO CA., 91710 · (800) 634-9166 · (909) 628-4722 · FACSIMILE (909) 591-2198

www.yoshimura-rd.com

Race Series

Qualified Manufacturer Declared "Modified Part"

2016~2018

Kawasaki ZX-10R

14182NP720 (Ti/CF)

Works Finish

Alpha Taper Titanium 3/4 System

FOR CLOSED COURSE COMPETITION ONLY; NOT INTENDED FOR STREET USE



Race Series systems are:

- NOT CARB/EPA tail-pipe emissions compliant.
- NOT street legal.
- For "Closed Course Competition" use only.



You must know how to remove and replace your stock exhaust in order to install this product otherwise have it installed by a professional mechanic. Keep all stock parts from your existing system as some components may be necessary to install your new Yoshimura exhaust depending on the application. Read through all instructions before beginning installation. Exhaust system can be extremely hot. Let motorcycle cool down before beginning installation. Always wear hand and eye protection and take precautionary measures to avoid injury.



NOTE: IN THE STATE OF CALIFORNIA, IT IS ILLEGAL TO MODIFY THE EMISSION CONTROL SYSTEM, WHICH INCLUDES THE CARBURETORS OF ANY VEHICLE.

Assembly Diagram

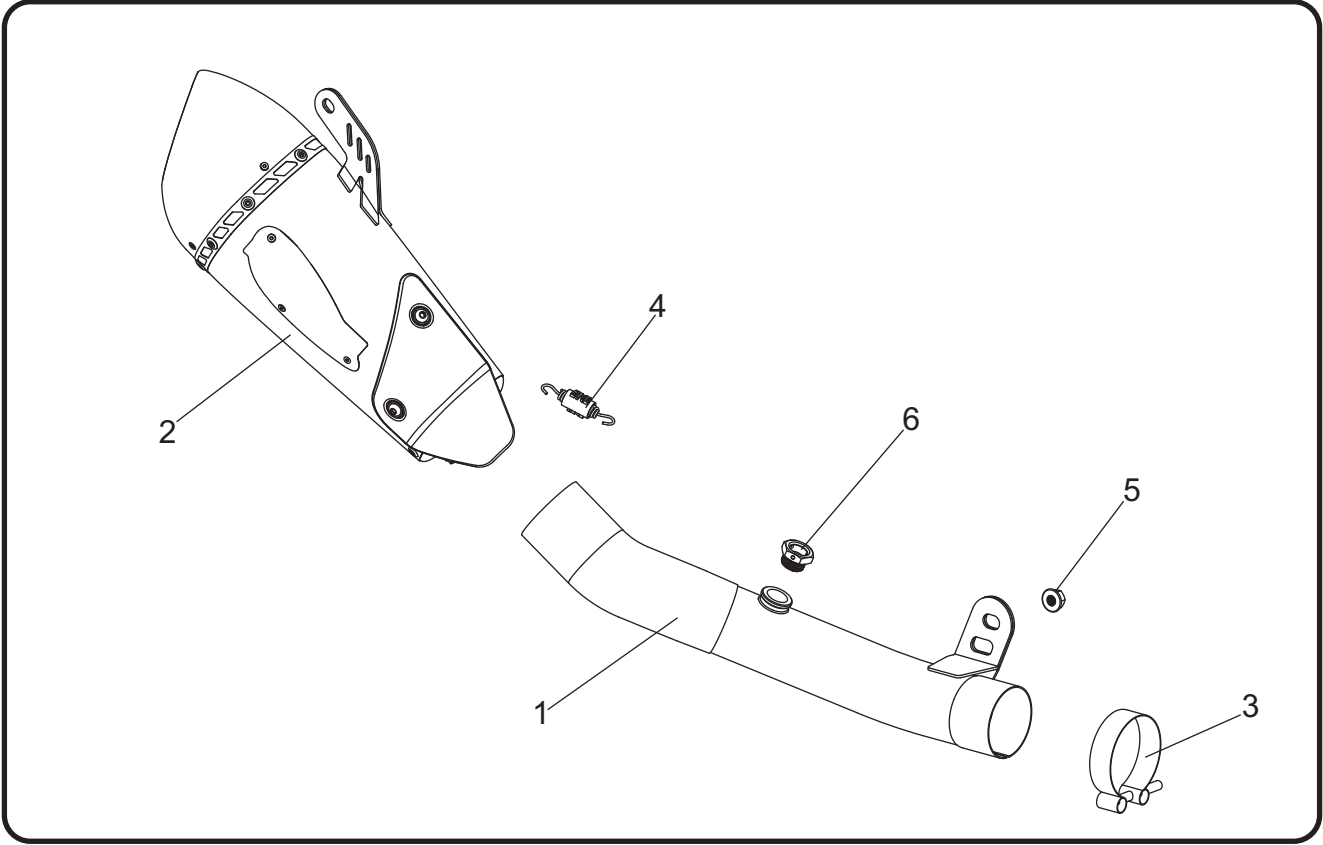

No.	Item	Description	Qty.
1	14182-714	Yoshimura Tailpipe	1
2	14182NP720-RMA	Ti/CF Muffler Assembly	1
3	20067	Exhaust Clamp	1
4	RACE-SPS-1	Medium Exhaust Spring	1
5	10MMFNUT	10mm Flange Nut	1
6	M18X9PLG	O2 Sensor Plug	1
**	INS-20-K	Low Volume Sound Insert	1
**	ST-200	Spring Puller Tool	1
**	17029	Sticker Kit Sheet	1

** Not shown in diagram.

CAUTION: Exhaust system can be extremely hot. Let motorcycle cool down before beginning installation. Always wear hand and eye protection and take precautionary measures to avoid injury.

WARNING: Always properly support vehicle with a stand and/or lift when servicing or performing any work. Unstable vehicles may present dangerous conditions and may cause property damage and/or personal injury.

NOTE: Read through all instructions before beginning installation.

Removal

1. Remove the stock heatshield between muffler and header to access exhaust clamp.
2. Loosen the muffler exhaust clamp and while securely supporting the stock muffler assembly, remove the muffler mount bolt and carefully remove the stock muffler assembly.
3. Remove the exhaust valve cover on the pre-muffler chamber to access exhaust valve cables.
4. Disconnect and remove exhaust valve cables from the pre-muffler chamber.

Note¹: Exhaust valve cables will not be used with the Yoshimura 3/4 system. Remove exhaust valve cables from servo motor.

Note²: Do not disconnect servo motor connector.

5. Loosen pre-muffler chamber exhaust clamp.
6. While securely supporting the pre-muffler chamber, remove the chassis mount bolt securing pre-muffler chamber and carefully remove by sliding toward the rear of vehicle.

Note: Exhaust gasket will not be reused with the Yoshimura 3/4 system.

Installation

1. Slide (No. 3) 20067, exhaust clamp over (No. 1) 14182-714, tailpipe inlet.

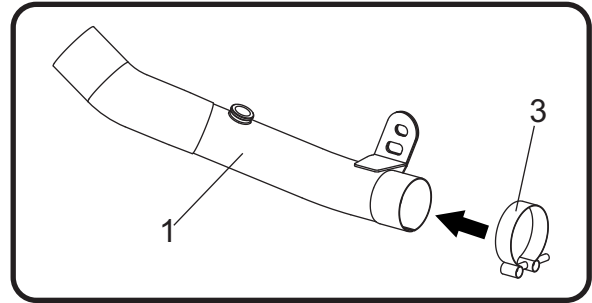

2. Install (No. 1) 14182-714, tailpipe over the stock header outlet and align tailpipe chassis mount bracket to chassis mount. Secure using the stock chassis mount bolt and (No. 5) 10MMFNUT, flange nut. Do not torque at this time.

Note: The tailpipe chassis mount bracket mounts to the front-side of chassis mount.

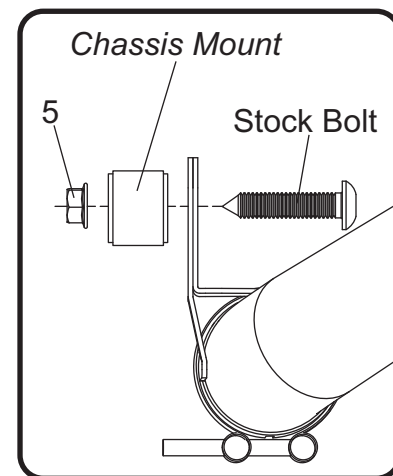

3. Install (No. 2) muffler over (No. 1) 14182-714, tailpipe outlet and align muffler bracket to the backside of the stock muffler mount. Secure using the stock bolt, washer, and nut.

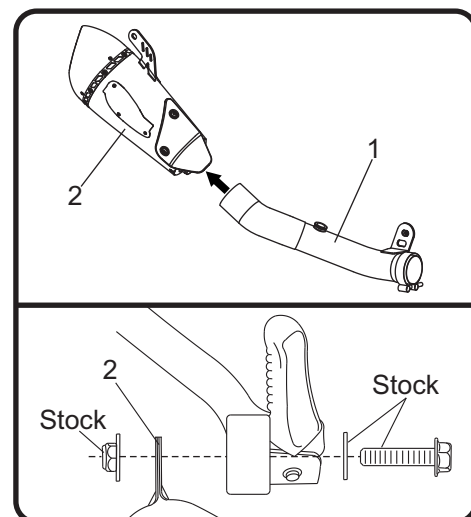

Works Finish Care & Maintenance

Before starting vehicle, clean pipe thoroughly using a soft cloth and rubbing alcohol to remove any oil and finger prints.

The color of the exhaust will change once the system has gone through a heat cycle of 15 minutes or more. Color will vary depending on lean/rich conditions.

Clean using a soft cloth and soap. Do not use abrasive materials as it will scratch the surface.

Surface reconditioning services are available to remove scratches and undesirable discoloration due to extreme heat. Contact Yoshimura Tech Department at (800) 634-9166 / in CA (909) 628-4722 for more information.

4. Install (No. 4) *RACE-SPS-1*, medium exhaust springs between muffler and tailpipe using *ST-200*, spring puller tool.
5. Torque muffler mount bolt to factory specification.
6. Torque chassis mount bolt to factory specification.
7. Torque (No. 3) *20067*, exhaust clamp to 8.5 Nm (0.86 kg-m, 6 ft-lb).
8. Install (No. 6) *M18X9PLG*, O2 sensor plug into (No. 1) *14182-714*, tailpipe if additional O2 sensor will not be used.

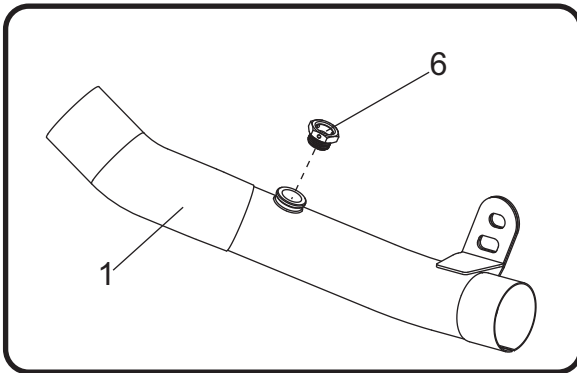

9. Before starting vehicle, check for proper clearance between new exhaust system and rear suspension (i.e. tire, swingarm, brakes, rear shock, and etc.) If any problem is found, please carefully follow through the installation steps again. If problem still persists, please call Yoshimura Tech Department at (800) 634-9166 / in CA (909) 628-4722.
10. It is recommended that the muffler and tailpipe be wiped down with rubbing alcohol to remove oil and fingerprints. This will help prevent tarnishing of the finish after the exhaust is heated up.

Note: After starting vehicle, it is normal for new exhaust system and muffler to emit smoke until oil residue burns off.