



## Custom Dynamics® Magical Wizard™ Indian® Wheel LED Light Kit Installation Instructions

We thank you for purchasing the Custom Dynamics® Magical Wizard™ Indian® Wheel LED Light Kit. Our products utilize the latest technology and high quality components to ensure you the most reliable service. We offer one of the best warranty programs in the industry and we back our products with excellent customer support, if you have questions before or during installation of this product please call Custom Dynamics® at 1(800) 382-1388.

**Part Number:** CD-IND-MWZ-WHEEL

**Package Contents:**

- Magical Wizard™ 30 LED Light Strip (2)
- 3M™ Tape Primer (1)
- Multi-Conductive wire (6 feet)
- 4" Tie Wraps (10)
- Heat Shrink Tubing (8)
- MagicFLEX® Mounting Stick (4)

**Required Item Sold Separately:**

Magical Color Command Remote (CCM-5)

**Optional Items Sold Separately:**

- Indian Engine LED Accent Light Kit (CD-IND-TMWK1 or CD-IND-TMWK1BM)
- Indian War Bonnet LED Accent Light Kit (CD-IND-WB-MWZ)
- Cage Clamp® (CG01) for wire connection (included w/lighting kits)
- Winter Kill Switch (SW01) to kill power to LED. (included w/lighting kits)
- Magical Wizard™ Install Kit (CD101-WZ)

**Fits:** Indian® Motorcycles With Wheel Fender Skirts.



**ATTENTION**

Please read all Information below before Installation

**Safety:** Always follow safe working practices including safety gear and the proper tools. Make sure the vehicle is cool enough to touch and secured on a level surface.

**Note:** Magical Wizard™ LEDs use the black wire for power and the colored wires for grounds. Please read instructions and diagrams before beginning installation.

**Important:** Disconnect negative battery cable from battery before installation; refer to owner's manual if unsure of this process. Failure to do so may result in electrical shock, injury, or fire. Secure negative battery cable away from positive side of battery and all other positive voltage sources on bike.

### Installation:

**Important:** Read all directions before starting project.

**Caution:** Always wear appropriate safety gear including safety glasses when soldering or performing any electrical work. It is highly recommended that safety glasses be worn throughout this installation process. Temperature of bike must be at least 60 degrees F. for tape to properly cure. Be sure bike is on level surface, secured and cool.

**Important:** Disconnect negative battery cable from battery; refer to owner's manual. Failure to do so may result in electrical shock, injury, or fire. Secure negative battery cable away from positive side of battery and all other positive voltage sources on bike.

**Note:** The Magical Wizard™ LED strips are longer than one mounting stick. A second mounting stick will need to be cut to the correct length to ensure the LEDs are mounted correctly.

### Front Wheel Instructions:

**Important:** The mounting sticks have 3M™ double sided tape on 3 sides. The widest side will mount to the fender and the LED light strip will mount at the bottom edge and face towards the ground. Ensure the LED light strip wire harness is toward the **REAR** of the bike before adhering the mounting stick to the fender.

1. Determine which will be the bottom edge of the mounting stick. Remove the protective cover from one of the MagicFLEX2® LED light strips and adhere to the downward facing edge of the mounting stick. Cut a second mounting stick to length. Make sure the LED strip is fully supported.
2. Repeat process for the other MagicFLEX2® LED light strip and mounting sticks.
3. Remove fender. Refer to your service manual for fender removal instructions.



Strip wire 9-10 mm. Use wire gauge on bottom to verify.



Push Lever up and insert wire...



Then push down lever to its closed position.

**Questions? Call us at: 1 (800) 382-1388 M-TH 8:30AM-5:30PM / FR 9:30AM-5:30PM EST**

## Installation Instructions - Page 2

- Cut the 22AWG wire in half so you have two 3' sections. Use these wires to extend the wire harness of the MagicFLEX2® LED strips.
- Place one piece of provided heat shrink tubing over the red, blue, green and black wires of the MagicFLEX2® LED strip. Using the provided 22 AWG wire, attach red wire to red wire, blue wire to blue wire, green wire to green wire and black wire to black wire by soldering or twisting the wires together. Slide the heat shrink over the connections and apply heat using a hair dryer or heat gun until heat shrink has shrunk around connections.
- Determine the desired location of the MagicFLEX2® LED light strips on both sides of the front fender and test fit.

**Important:** Make sure the wire harness of the LED lights are pointing toward the REAR of the bike before adhering to the fender.

- Apply 3M™ primer on the determined location and allow to dry.
- Remove the red protective tape from the wide side of the MagicFLEX® mounting sticks and press into place on the left and right side of the fender.
- Re-install the front fender. Refer to your service manual for fender installation instructions.
- Route the wire harnesses with the brake lines to the fairing and attach using the tie wraps included.
- Continue routing the MagicFLEX2® LED light strip wire harnesses back to a central point near battery compartment under seat. Route wires such that they not interfere with normal operation of bike. Cut off any excess wires, strip back insulation as required.

**Caution:** Ensure the MagicFLEX2® wire harness is not touching the engine.

- Secure wires to the frame using some of the tie wraps provided.

**Note:** If installing with Indian Engine Accent Light Kit (M2EK1-IND), stop here and follow the wiring instructions for that kit.

- See page 4 for wiring the MagicFLEX2® LED light strips to the Magical Color Command Remote.

**Caution:** DO NOT allow any tools to touch both positive (+) side of battery and any metal surface on bike as it will cause a short which could result in serious injury and damage to the battery or other electrical circuits.

- Secure any remaining wires with tie wraps.
- Connect the negative (-) cable to the battery.
- Turn on switch and check operation of all lights.

### Rear Wheel Instructions:

**Important:** The mounting sticks have 3M™ double sided tape on 3 sides. The widest side will mount to the fender and the LED light strip will mount at the bottom edge and face towards the ground. Ensure the LED light strip wire harness is toward the **FRONT** of the bike before adhering the mounting stick to the fender.

- Determine which side will be the bottom edge of the mounting stick. Remove the protective cover from one of the MagicFLEX2® LED light strips and adhere to the downward facing edge of the mounting stick. Cut a second mounting stick to length. Make sure the LED strip is fully supported.
- Repeat process for the other MagicFLEX2® LED light strip and mounting stick.
- Cut the 22AWG wire in half so you have two 3' sections. Use these wires to extend the wire harness of the MagicFLEX2® LED strips.
- Place one piece of provided heat shrink tubing over the red, blue, green and black wires of the MagicFLEX2® LED strip. Using the provided 22 AWG wire, attach red wire to red wire, blue wire to blue wire, green wire to green wire and black wire to black wire by soldering or twisting the wires together. Slide the heat shrink over the connections and apply heat using a hair dryer or heat gun until heat shrink has shrunk around connections.
- Determine desired location for mounting the LED light strips. Test fit the lights before removing the protective cover off the 3M™ tape.

**Note:** The suggested location is just above the bottom inside of both left and right fender skirts. Start the LED light strip at the front of the skirt closest to the seat. Follow the edge of the skirt until the strip ends.

**Important:** Make sure the wire harness of the LED lights are pointing toward the FRONT of the bike before adhering to the fender.

- After test fitting the LED light strips at desired location, apply 3M™ primer to the fender and allow to dry.
- Remove the red protective tape from the wide side of the MagicFLEX® mounting stick and press into place on the left and right side of the fender.

**Questions? Call us at: 1 (800) 382-1388 M-TH 8:30AM-5:30PM / FR 9:30AM-5:30PM EST**

## Installation Instructions - Page 3

### Installing the Weatherproof Kill Switch (SW01 sold separately)

**NOTE:** When the CCM remote has power, it will constantly search for a key fob signal. Long periods of down time, such as storing vehicle over the winter, will drain the battery. It is recommended you turn off power going to the remote using the weatherproof push button kill switch. Use the Diagram on page 2 for the exact location to install the switch.

1. Cut the Red power wire between the fuse holder and the harness connector, see the diagram on page 2.
2. Use butt splice or wire tap to connect the switch to the red wire on the connector side of the harness.
3. Use butt splice or wire tap to connect the other side of the switch to the fuse holder side of the harness.
4. Mount the switch in convenient location with the included double-sided tape. Prime the surface with the 3M™ primer and allow to dry.

### Finish and Test

1. Inspect all connections, make sure nothing is loose, frayed, pinched or cut. A direct short will prevent the unit and LED's from functioning properly.
2. Re-connect the Negative [ - ] cable to the battery, turn the vehicle power on and test function with the key fobs. See instructions that come with the CCM-5 for operating the Key Fobs.
3. Once the system has been tested, dress the wires with provided tie-wraps as needed. Make sure the receiver and wiring is tucked out of the way from any heat or moving parts.



Ensure there is enough clearance for the wiring and remote box underneath the seat without crushing or pinching any of the components or connections. This is very important! A frayed or pinched wire can short the entire lighting system.

### Troubleshooting

This section will go over a few of the most common troubleshooting issues with the Magical Wizard™ LEDs and the CCM remote and give tips to help get your system up and running. If after you have tried any of these and still have issues, call Custom Dynamics® for technical support.

Symptom: Key Fob light not coming on \_\_\_\_\_ Remedy: Check and replace key fob batteries

Symptom: Dim or pulsing blue light on key fob \_\_\_\_\_ Remedy: Check and replace key fob batteries

Symptom: Dim lights or lights not turning off completely \_\_\_\_\_ Remedy: Grounding issue - With process of elimination, trace back all LED wires checking for nicks or cuts in wires. If nothing is found, remove LED's 1 by 1 and test system function each time.

Symptom: Lights only get certain colors when on \_\_\_\_\_ Remedy: Inspect wires in all cage clamps, make sure all wires are pushed into sockets completely. Start with color you are not getting, red, green or blue.

Symptom: Lights not coming on, key fob lights up \_\_\_\_\_ Remedy 1: Inspect the wires in the cage clamps. Make sure red and black wires are pushed into the sockets all the way. Also double check connections at the battery.

Remedy 2: Check and or replace 7.5 amp in-line fuse.

# Installation Instructions - Page 4

## Wiring LED and CCM-5:

1. Using the (4) Cage Clamp® connectors (sold separately) or some other way of connection, label each clamp with a number 1 through 4. If you need instructions on how to use the Cage Clamps®, see instructions on page 1.
2. LED's BLACK wire into Cage Clamp® #1 with CCM-5 White wire.
3. LED's RED wire into Cage Clamp® #2 with CCM-5 Red wire (non-fused).
4. LED's BLUE wire into Cage Clamp® #3 with CCM-5 Blue wire.
5. LED's GREEN wire into Cage Clamp® #4 with CCM-5 Green wire.
6. CCM-5 Red (fused) wire to bike's battery positive (+) terminal.
7. CCM-5 Black wire to bike's battery negative (-) terminal.
8. Make sure all connections are secure in the clamp and will not pull out.

Magical Wizard™  
War Bonnet LED

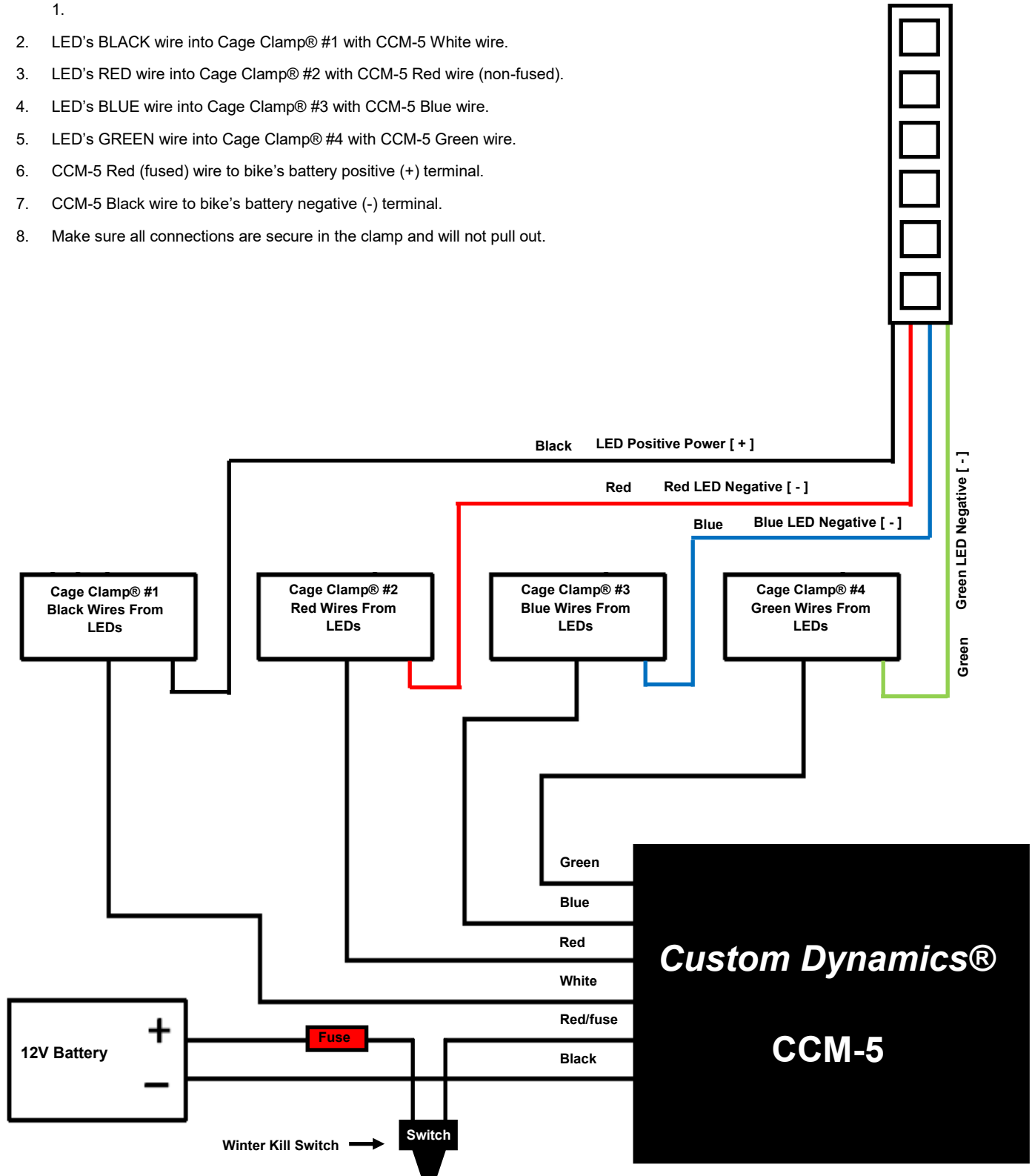

Questions? Call us at: 1 (800) 382-1388 M-TH 8:30AM-5:30PM / FR 9:30AM-5:30PM EST