

PROBEAM®

BY CUSTOM DYNAMICS®

Custom Dynamics® ProBEAM® 7” Adaptive LED Headlamp Installation Instructions

We thank you for purchasing the Custom Dynamics® ProBEAM® LED headlamp! Our products utilize the latest technology and high quality components to ensure you the most reliable service. We offer one of the best warranty programs in the industry and we back our products with excellent customer support, if you have questions before or during installation of this product please call Custom Dynamics® at 1(800) 382-1388.

Part Number: PB-7A14-B PB-7A14-C

Package Contents:

- ProBEAM® 7” Adaptive LED Headlamp (1)
- H4-TOUR-ADAPTER
- Instructions

Fits: 2014-2022 Harley-Davidson® Street Glide (FLHX), Street Glide Special (FLHXS), Street Glide ST (FLHXST), CVO™ Street Glide (FLHXSE), Electra Glide Standard (FLHT), Electra Glide Ultra Classic (FLHTCU), Electra Glide Ultra Classic Lo (FLHTCUL), Ultra Limited (FLHTK), Ultra Limited Lo (FLHTKL), CVO™ Limited (FLHTKSE), Road King (FLHR), Road King Special (FLHRXS) and CVO™ Road King (FLHRSE), Tri Glide Ultra (FLHTCUTG), CVO™ Tri Glide (FLHTCUTGSE), Freewheeler (FLRT) & 1984-2017 FL Softail models with OEM 7” headlight buckets.

Note: 2014-2022 Harley-Davidson® Road King (FLHR), 2017-2020 Road King Special (FLHRXS), and 2020-2022 Freewheeler (FLRT) models require wiring adapter 2001-1264 (sold separately).



Installation:

1. Disconnect the vehicle battery negative [-] terminal.
2. Review detailed service manual for instructions on replacing factory headlamp.
3. Remove the factory headlamp from vehicle.
4. Connect the ProBEAM® headlamp to the existing factory H4 plug and re-install according to your detailed service manual. Make sure no wire or any components of the harness can be pinched during installation and that they will not be exposed to water spray, excessive heat or moving parts.

Note: 2014-2022 Street Glide, Electra Glide, Ultra, Tri Glide models (Including CVO™), 2014 Road King CVO™ and 2021-2022 Road King Special models need to use the included H4-TOUR-ADAPTER. If your headlight electrical harness connector does not match the flat 4 pin connector of the H4-TOUR-ADAPTER, follow your bike’s harness back into the fairing until you find your bike’s flat 4 pin connector.

Note: The Red (position light or city light) wire is intended for international application which may require a position light to be illuminated in the headlight while the bike is parked on a street. It will be connected to the accessory circuit of the bike’s harness and will illuminate when the ignition is placed in the accessory position.

U.S. Bikes will not need this and it should be secured to the headlight harness with wire ties.

5. Re-connect vehicle battery negative [-] terminal.
6. Test high and low beam functions of headlamp.



ATTENTION

Please read all Information below before Installation

Important: Due to the increased light output from this unit, it is recommended you take the vehicle to a dealer to have the headlamp properly adjusted. Weight and tire pressure can affect the position of the light.

Warning: To prevent possible electrical shock, disconnect the negative battery terminal before installing this product.

Questions? Call us at: 1 (800) 382-1388 M-TH 8:30AM-5:30PM / FR 9:30AM-5:30PM EST

Installation Instructions - Page 2

Using the H4-TOUR-ADAPTER on 2014-2022 H-D™ Touring Models

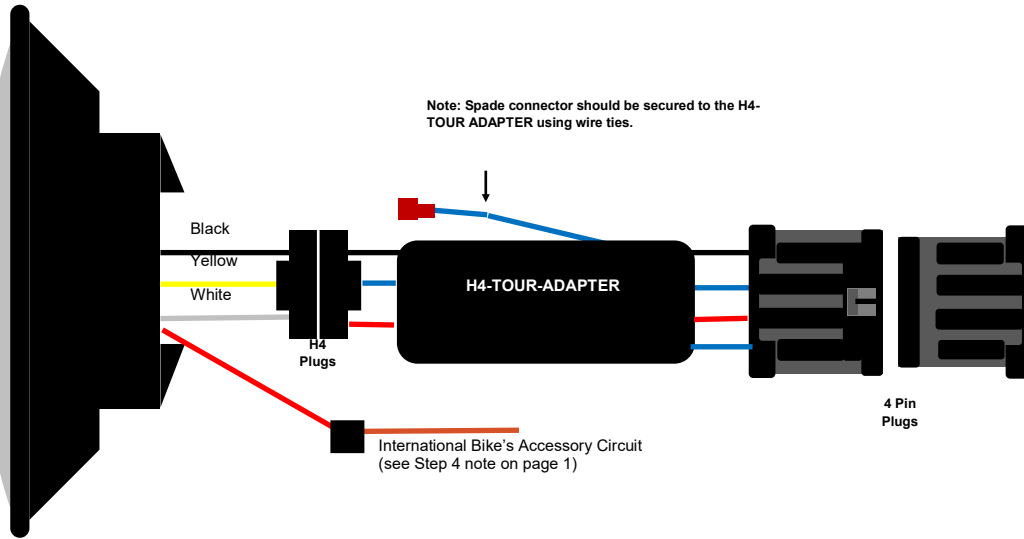

Using the CDTB-H42H9H11 (Sold Separately) on 2014-2022 H-D™ Road King Models and 2020-2022 Freewheeler (FLRT)

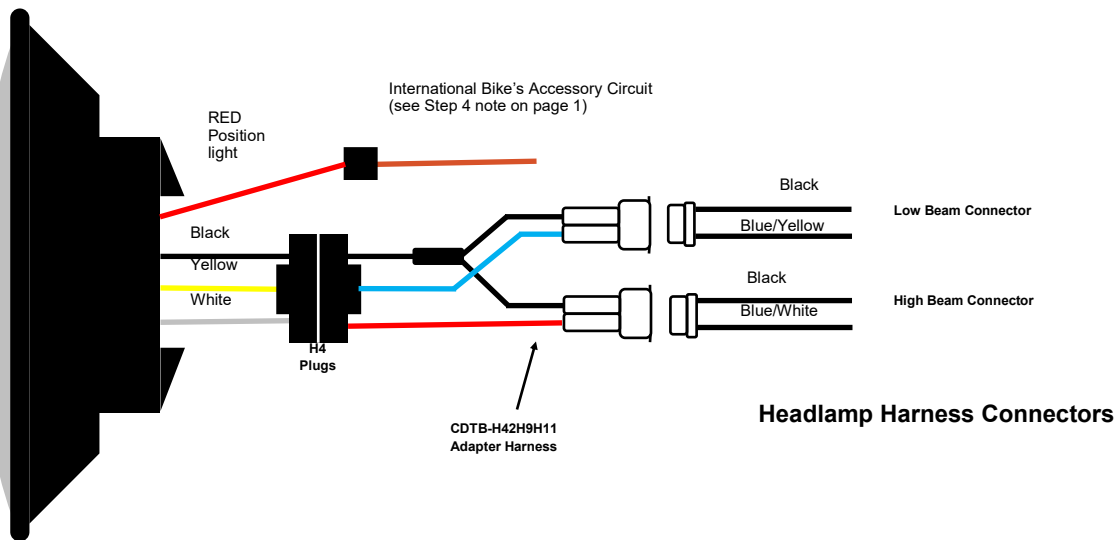

Questions? Call us at: 1 (800) 382-1388 M-TH 8:30AM-5:30PM / FR 9:30AM-5:30PM EST