

Kofferträger
YAMAHA FZ 1 Fazer ab 2006

Artikel-Nr.:
650.4522.00 01 schwarz



- Seitenkoffer
- Topcases
- Gepäckträger
- Lock it System
- Softbags
- Aluminiumkoffer
- Lederkoffer
- Schutzbügel
- Hauptständer
- Chopper-Parts
- Quad-Parts
- Accessoires



Montage

Der Bausatz umfaßt die folgenden Teile:

Stück	Bestellnr.	Bezeichnung	Stück	Bestellnr.	Bezeichnung
1	704.079HB	Kofferträger, links	4	151.139	Sechskantschraube M 6 x 12
1	704.080HB	Kofferträger, rechts	2	150.784	Inbusschraube M 8 x 30
1	704.294HB	Adapterbügel	4	150.761	Inbusschraube M 6 x 16
1	704.295HB	Blinkerhalter	6	151.070	Lock-it Systemschraube
1	704.296HB	Adapterlasche unten links	6	151.071	Lock-it Sicherungsscheibe
1	704.297HB	Adapterlasche unten rechts	8	150.809	U-Scheibe ø6,4
1	704.298HB	Adapterlasche oben links	8	150.810	U-Scheibe ø8,4
1	704.299HB	Adapterlasche oben rechts	2	150.995	U-Scheiben ø8,4 x 3mm
1	704.300HB	Querbügel	2	150.811	U-Scheiben ø10,5
2	150.892	Linsenkopfschraube M 8 x 45	2	150.706	Karoseriescheiben ø8,4 x ø30
2	150.886	Linsenkopfschraube M 8 x 40	2	150.986	Karoseriescheiben ø6,4 x ø18
2	150.923	Linsenkopfschraube M 8 x 30	4	150.799	Selbstsichernde Mutter M6
2	150.891	Linsenkopfschraube M 8 x 25	2	150.800	Selbstsichernde Mutter M 8
			2	150.803	Tensilockmutter M8

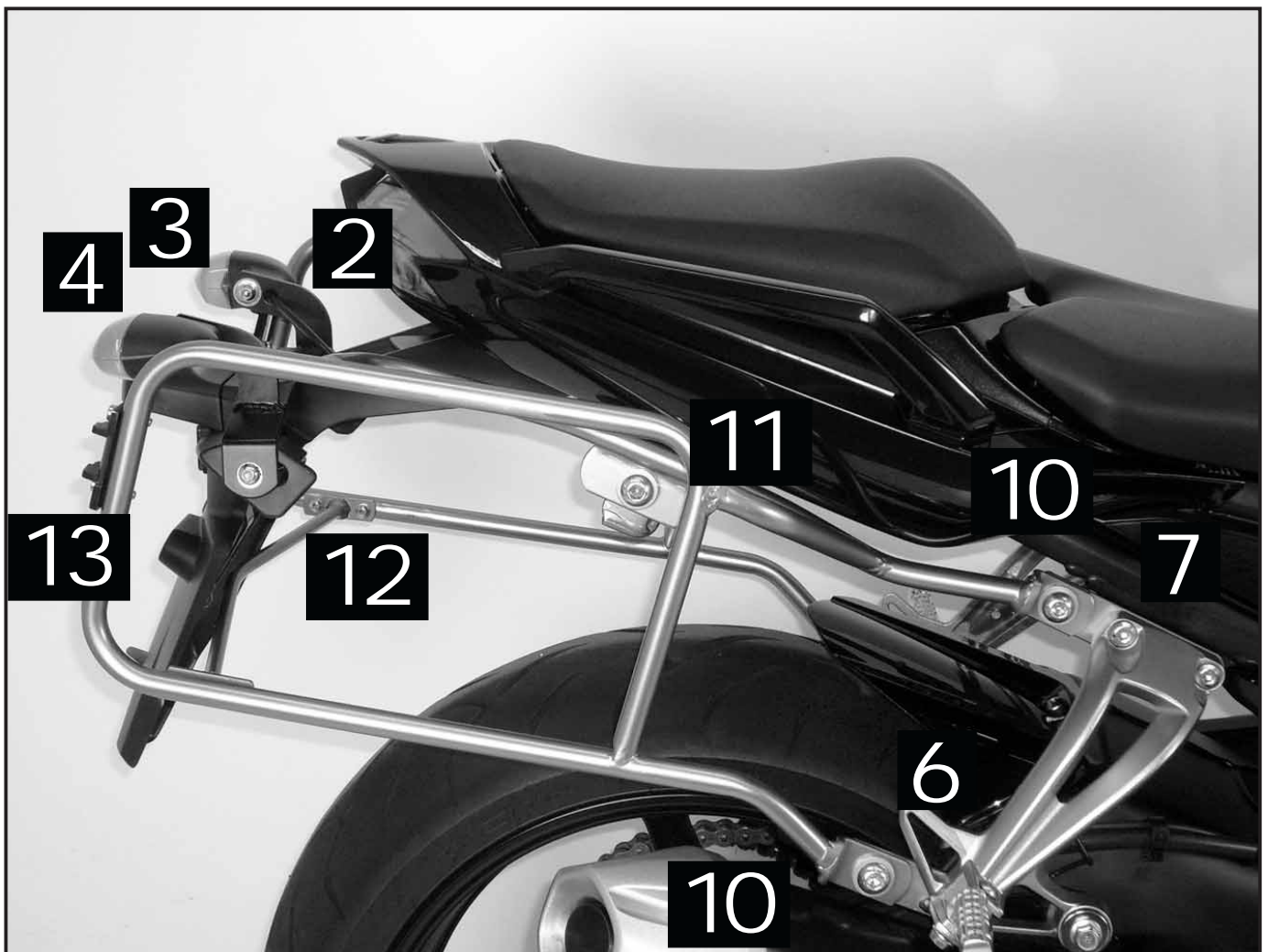

Kofferträger
YAMAHA FZ 1 Fazer ab 2006

Artikel-Nr.:
650.4522.00 01 schwarz



- Seitenkoffer
- Topcases
- Gepäckträger
- Lock it System
- Softbags
- Aluminiumkoffer
- Lederkoffer
- Schutzbügel
- Hauptständer
- Chopper-Parts
- Quad-Parts
- Accessoires



Montage

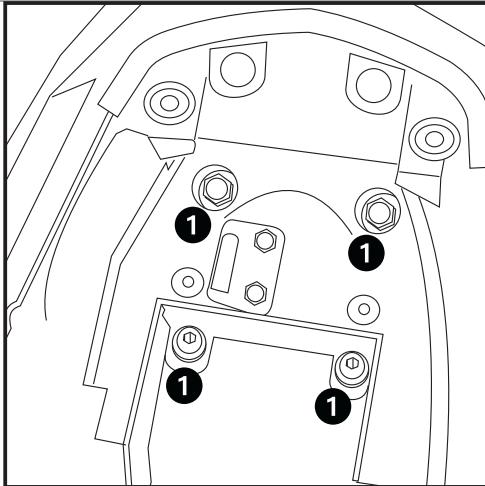

1

Vorbereitung:

Soziussitz demontieren.

Den Nummernschildträger mit den Blinkern demontieren, dazu die Schrauben 1 unter der Sitzbank lösen.

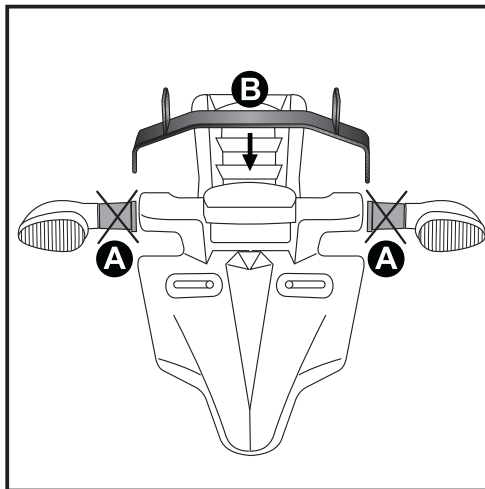

2

Befestigung des Blinkerhalters:

Die Blinker demontieren. Die Gummiteile A der Blinker demontieren; sie entfallen.

Der Blinkerhalter B wird an der Originalposition der Blinker plziert.

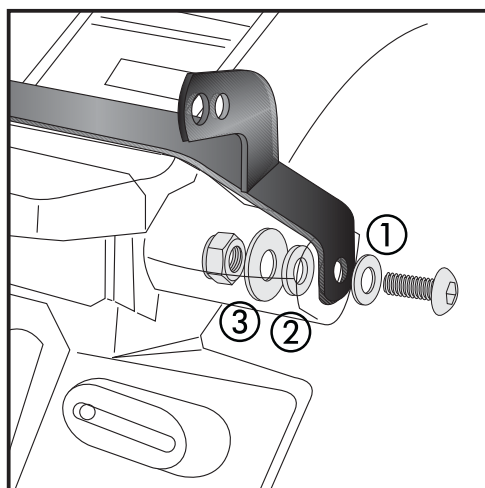

3

Befestigung des Blinkerhalters:

Zur Montage von innen zuerst die U-Scheiben $\varnothing 8,4 \times 3$ mm dick einlegen, dann folgen die Karoseriescheiben $\varnothing 8,4 \times \varnothing 30$ innen. Zur Befestigung die Linsenkopfschrauben M 8 x 25 mit U-Scheiben $\varnothing 8,4$ und selbstsichernde Muttern M 8 verwenden.

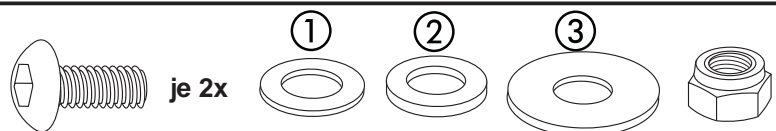

Kofferträger
YAMAHA FZ 1 Fazer ab 2006

Artikel-Nr.:
650.4522.00 01 schwarz



Seitenkoffer
Topcases
Gepäckträger
Lock it System
Softbags
Aluminiumkoffer
Lederkoffer
Schutzbügel
Hauptständer
Chopper-Parts
Quad-Parts
Accessoires



Montage

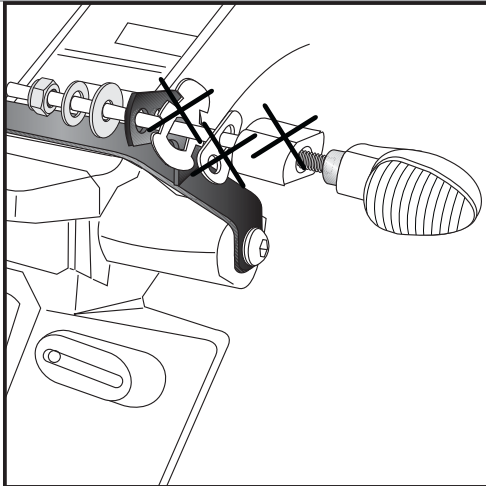

4

Befestigung des Blinker:

Am zuvor montierten Blinkerhalter. Die Blinkerverlängerung entfällt. Jeweils eine U-Scheibe $\varnothing 10,5$ und Karosseriescheibe $\varnothing 6,4 \times \varnothing 18$ unterlegen. Zur Verschraubung die Originalmutter M5 verwenden.

Die Blinkerkabel werden durch die untere Öffnung des Nummernschildträgers und dann wie original verlegt. Sie müssen nicht verlängert werden.

je 2x

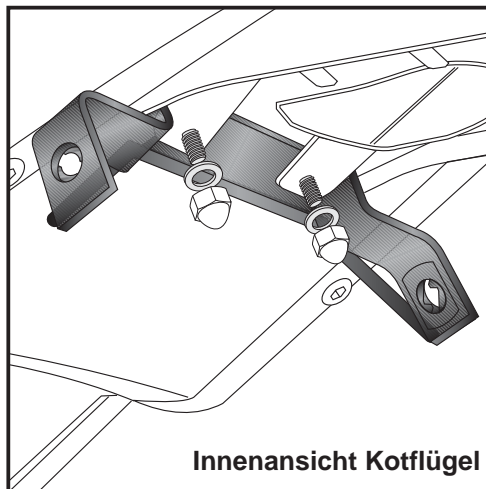

Innenansicht Kotflügel

5

Montage des Adapterbügels:

Den Nummernschildträger wieder montieren.

Dabei auf der Kotflügelinnenseite den Adapterbügel zwischen Kunststoffteil und Metallverstärkung des Nummernschildträgers verschrauben.

Von oben die Inbusschrauben M8 x 30 mit U-Scheiben $\varnothing 8,4$ durchstecken und von unten die Original-Hutmuttern benutzen.

je 2x

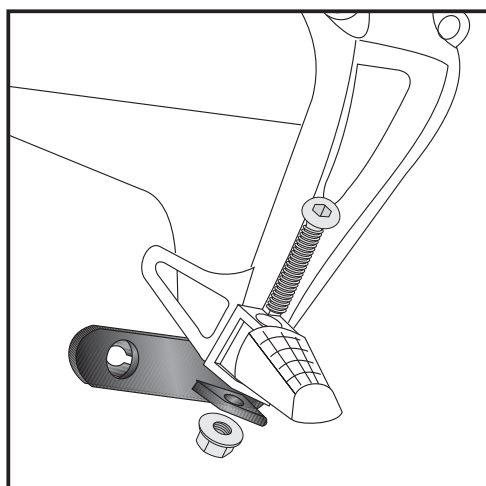
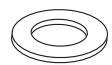
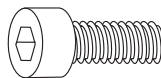

6

Montage der Adapterlaschen unten links und rechts:

Diese werden an den Soziusfußrasten befestigt.

Dazu die Haltebolzen der Fußrasten ausbauen und durch die Linsenkopfschrauben M8 x 45 ersetzen.

Adapterlaschen auf das überstehende Gewinde schieben und mit Tensillockmutter M8 verschrauben.

je 2x

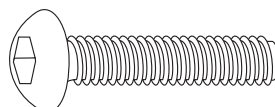

Kofferträger
YAMAHA FZ 1 Fazer ab 2006

Artikel-Nr.:
650.4522.00 01 schwarz



Seitenkoffer
Topcases
Gepäckträger
Lock it System
Softbags
Aluminiumkoffer
Lederkoffer
Schutzbügel
Hauptständer
Chopper-Parts
Quad-Parts
Accessoires



Montage

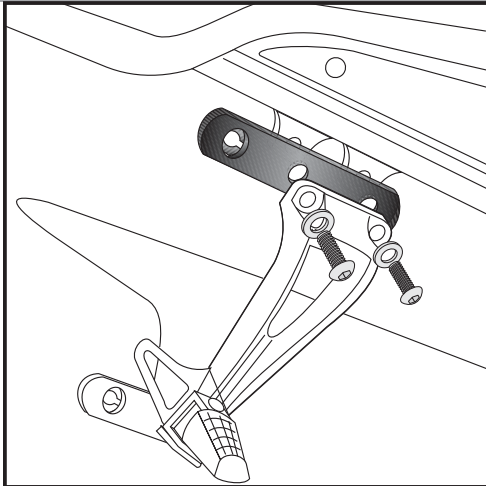

7 Rechte Seite

Befestigung der Adapterlasche oben rechts:
zwischen Rahmen und Soziusfußrastenausleger mit der
Linsenkopfschraube M8 x 30 und U-Scheibe $\varnothing 8,4$.
Dazu den Fußrastenausleger demontieren, die Originalschrauben
entfallen.

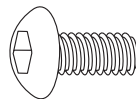

je 2x

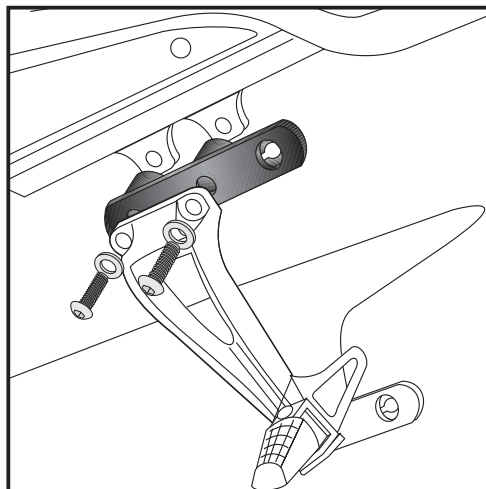

8 Linke Seite

Befestigung der Adapterlasche oben links:
Diese Adapterlasche verfügt über angeschweißte Distanzen.
Montage zwischen Rahmen und Soziusfußrastenausleger mit der
Linsenkopfschraube M8 x 40 und U-Scheibe $\varnothing 8,4$.
Dazu den Fußrastenausleger demontieren, die Originalschrauben
entfallen.

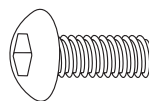

je 2x

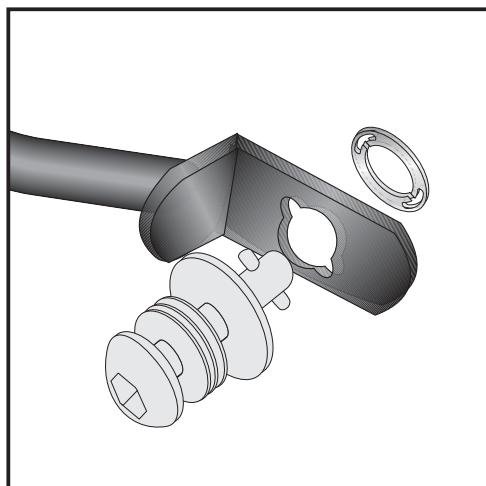

9

Montage der Lock it System-Schrauben:
An den Kofferträgern links / rechts werden die Lock it System-
Schrauben an den Befestigungslaschen mittels der Sicherungs-
scheibe montiert.
Die Scheiben und Lock it System-Schrauben verbleiben bei
Demontage an den Befestigungspunkten der Kofferträger.

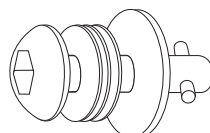

6x



Kofferträger
YAMAHA FZ 1 Fazer ab 2006

Artikel-Nr.:
650.4522.00 01 schwarz



Seitenkoffer
Topcases
Gepäckträger
Lock it System
Softbags
Aluminiumkoffer
Lederkoffer
Schutzbügel
Hauptständer
Chopper-Parts
Quad-Parts
Accessoires



Montage

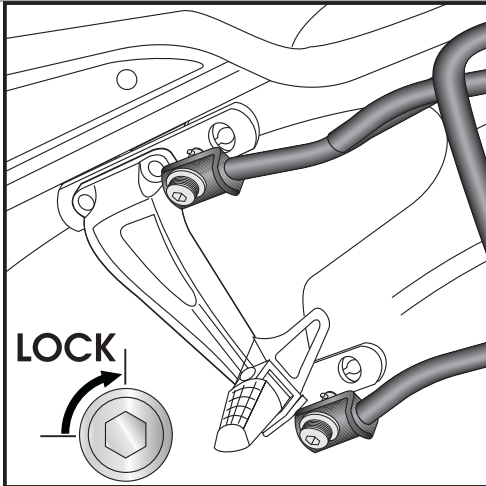

10

Montage der Kofferträger links / rechts:

Die vorbereiteten Kofferträger werden an den Haltetaschen mittels der Lock it System-Schrauben befestigt.

ACHTUNG:

Lock it System-Schrauben nicht überdrehen !
Langsam drehen (Viertelumdrehung) bis die Schraube fühlbar einrastet und am Anschlag anliegt.

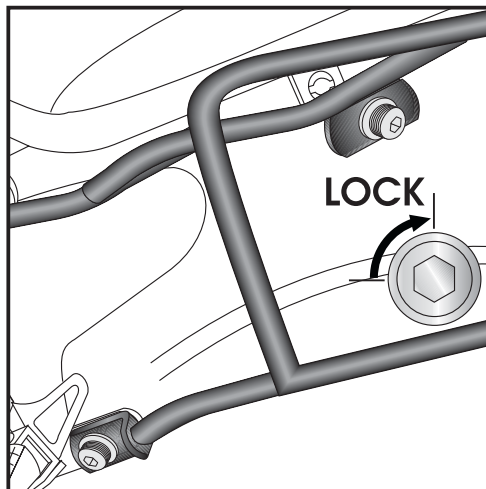

11

Montage der Kofferträger links / rechts:

Die vorbereiteten Kofferträger werden an den Haltetaschen mittels der Lock it System-Schrauben befestigt.

ACHTUNG:

Lock it System-Schrauben nicht überdrehen !
Langsam drehen (Viertelumdrehung) bis die Schraube fühlbar einrastet und am Anschlag anliegt.

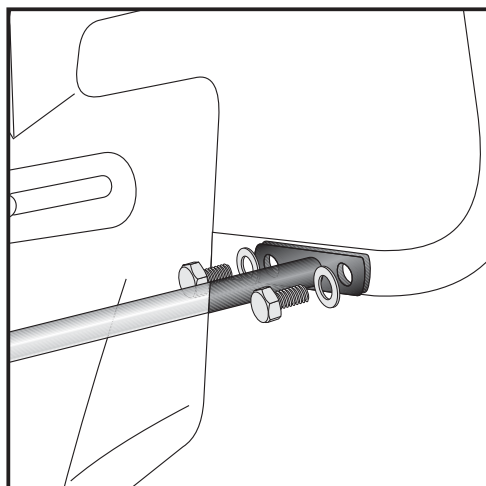

12

Befestigung des Querbügels:

Diese verläuft innen hinter dem Nummernschildhalter.
Der Querbügel wird an den Gewindebohrungen der Kofferträger mit den Sechskantschrauben M 6 x 12 und U-Scheiben ø6,4 verschraubt.

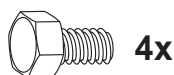

Kofferträger
YAMAHA FZ 1 Fazer ab 2006

Artikel-Nr.:
650.4522.00 01 schwarz



Seitenkoffer
Topcases
Gepäckträger
Lock it System
Softbags
Aluminiumkoffer
Lederkoffer
Schutzbügel
Hauptständer
Chopper-Parts
Quad-Parts
Accessoires



Montage

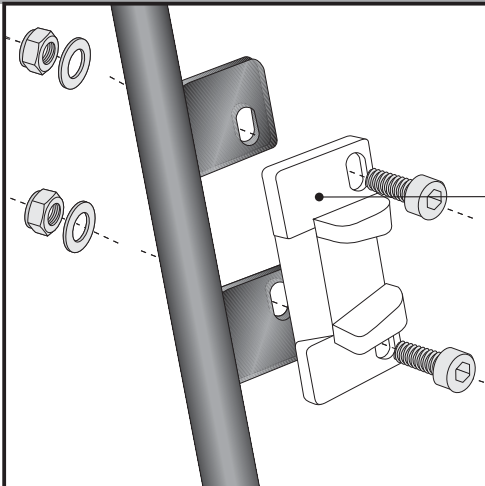

13 Hinweise zur Koffermontage

Montage des Metalladapters zum Einhängen des Kofferhalteschlosses

HINWEIS :
die Metalladapter liegen den Koffern bei, nicht diesem Kofferträgerset.

Die notwendigen Schrauben zur Montage der Metalladapter am Kofferträger sind beigelegt (Inbusschrauben M6 x 16, U-Scheiben $\varnothing 6,4$, selbstsichernde Muttern M6).

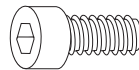

je 4x



Anzugsmomente des Motorradherstellers beachten!
Nach der Montage alle Verschraubungen auf festen Sitz kontrollieren!
Bitte beachten Sie unsere beigelegten Serviceinformationen.

Als weiteres Zubehör lieferbar:

501.420 01 01 Motorschutzbügel schwarz



Hepco & Becker GmbH
An der Steinmauer 6

D-66955 Pirmasens

Tel.: +49 (0)6331 - 1453 - 100
Fax: +49 (0)6331 - 1453 - 120
eMail: vertrieb@hepco-becker.de
www.hepco-becker.de

Side carrier
YAMAHA FZ 1 Fazer from 2006

Item - No.:
650.4522.00 01 black



Assembling instructions

- Side cases
- Top cases
- luggage frames
- Lock it system
- Softbags
- Aluminium luggage
- Leather luggage
- Protection bars
- Center stands
- Chopper parts
- Quad parts
- Accessories



The kit includes the following parts:

Quant	item no.	description	Quant	item no.	description
1	704.079HB	carrier left	4	151.139	hexagon bolt M 6 x 12
1	704.080HB	carrier right	2	150.784	allen screw M 8 x 30
1	704.294HB	mounting bracket	4	150.761	allen screw M 6 x 16
1	704.295HB	blinker mounting	6	151.070	lock it screw
1	704.296HB	mounting adapter left, bottom	6	151.071	lock washer
1	704.297HB	mounting adapter right, bottom	8	150.809	washer ø6,4
1	704.298HB	mounting adapter left, top	8	150.810	washer ø8,4
1	704.299HB	mounting adapter right, top	2	150.995	washer ø8,4 x 3mm
1	704.300HB	bracing bow	2	150.811	washer ø10,5
2	150.892	filister head screw M 8 x 45	2	150.706	body washer ø8,4 x ø30
2	150.886	filister head screw M 8 x 40	2	150.986	body washer ø6,4 x ø18
2	150.923	filister head screw M 8 x 30	4	150.799	self-nock nut M6
2	150.891	filister head screw M 8 x 25	2	150.800	self-nock nut M 8
			2	150.803	tensilock nut M8

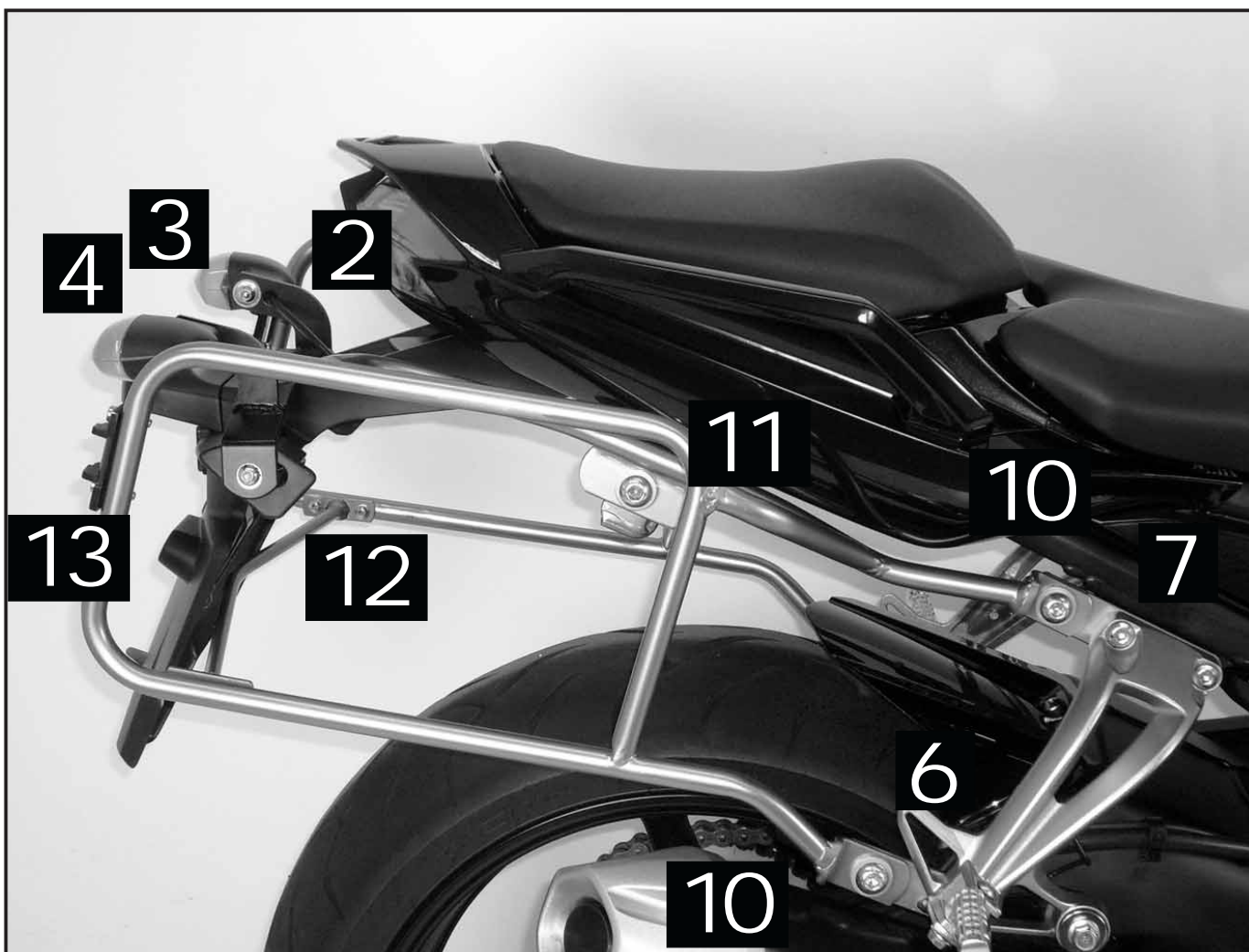

Side carrier
YAMAHA FZ 1 Fazer from 2006

Item - No.:
650.4522.00 01 black



Assembling instructions

Side cases

Top cases

luggage frames

Lock it system

Softbags

Aluminium luggage

Leather luggage

Protection bars

Center stands

Chopper parts

Quad parts

Accessories

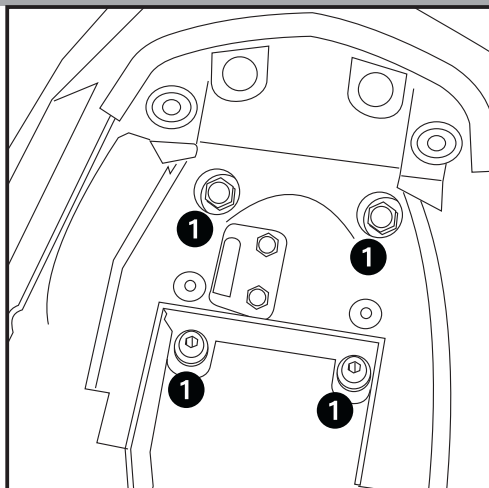

1

Preparing:

Unmount seat.

Unmount number plate holder (screws marked with 1)

Tip:

Fit all parts and screw on not too strong.

After mounting all parts, the screws should be tightened to the torque specified.

This guarantees, that the kit is mounted without tension.

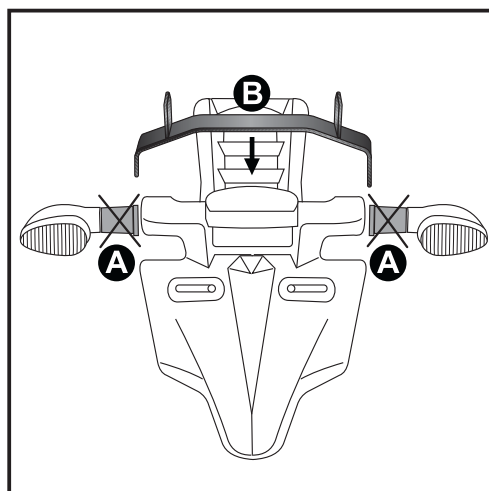

2

Unmount blinker.

The rubber parts of the blinker (A) are not needed any more.

The blinker mounting will be placed instead of the blinkers. (B)

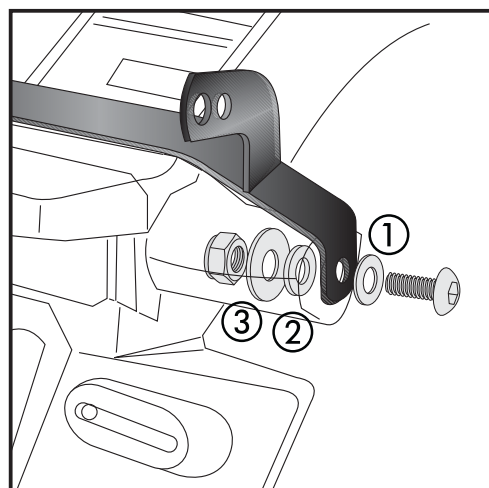

3

Fastening of the blinker mounting:

At the inner side:

use washer $\varnothing 8,4 \times 3$ mm, body washer $\varnothing 8,4 \times \varnothing 30$ and self-lock nut M8.

Outside use washer $\varnothing 8,4$ and filister head screw M8 x 25.

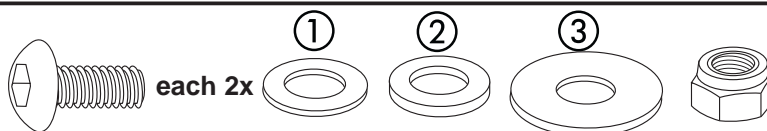

Luggage ideas.

Side carrier
YAMAHA FZ 1 Fazer from 2006

Item - No.:
650.4522.00 01 black



Assembling instructions

Side cases
Top cases
luggage frames
Lock it system
Softbags
Aluminium luggage
Leather luggage
Protection bars
Center stands
Chopper parts
Quad parts
Accessories

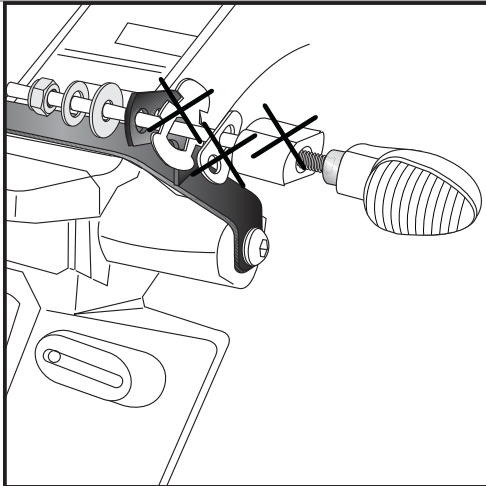

4

Fastening of the blinker:
with original nut at the blinker mounting.
Sandwich a washer $\varnothing 10,5$ and a body washer $\varnothing 6,4 \times \varnothing 18$.

each 2x

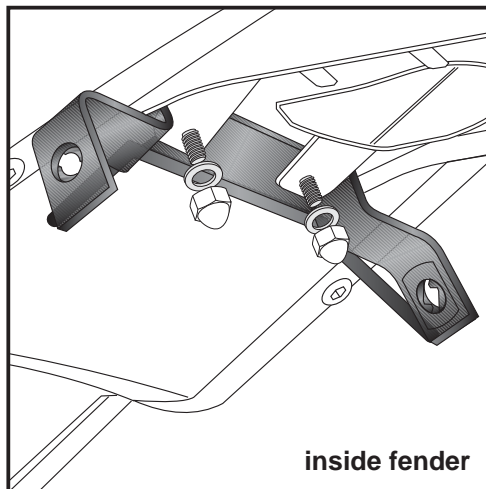
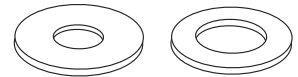

5

Fastening of the mounting bracket:
Mount number plate holder again.
Sandwich mounting bracket between plastic and metal of the number plate holder.
Use allen screws M8 x 30 with washers $\varnothing 8,4$ from above and inside fender the original cap nuts.

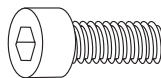

each 2x

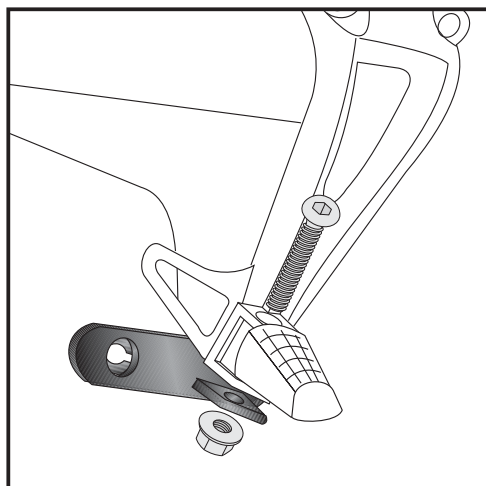
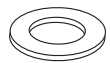

6

Fastening of mounting adapter left, bottom:
At the footrest brackets.
Use filister head screw M8 x 45 and tensilock-nut M8.
Original bolt is not needed any more.

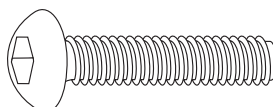

each 2x



Side carrier
YAMAHA FZ 1 Fazer from 2006

Item - No.:
650.4522.00 01 black



Assembling instructions

- Side cases
- Top cases
- luggage frames
- Lock it system
- Softbags
- Aluminium luggage
- Leather luggage
- Protection bars
- Center stands
- Chopper parts
- Quad parts
- Accessories

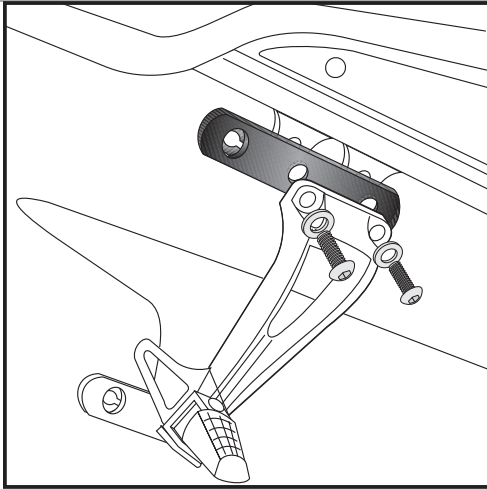

7 right side

Fastening of mounting adapter right, top:
Between frame and footrest bracket holder.
Use filister head screws M8 x 30 and washers ø8,4.
Original screws are not needed any more.

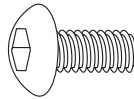

each 2x

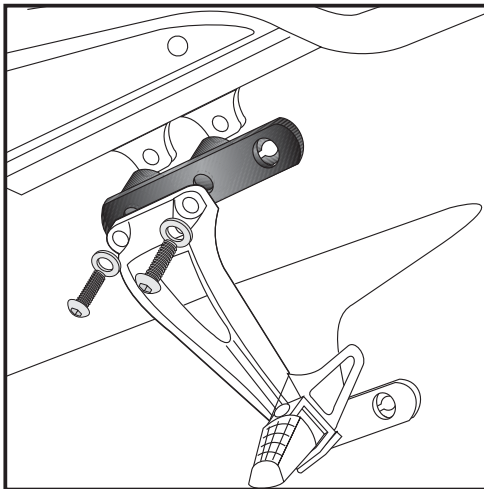
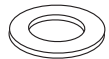

8 left side

Fastening of mounting adapter left, top:
Between frame and footrest bracket holder.
The left mounting adapter has integrated spacers.
To fix, use filister head screws M8 x 40 and washers ø8,4.
Original screws are not needed any more.

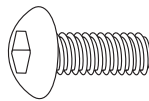

each 2x

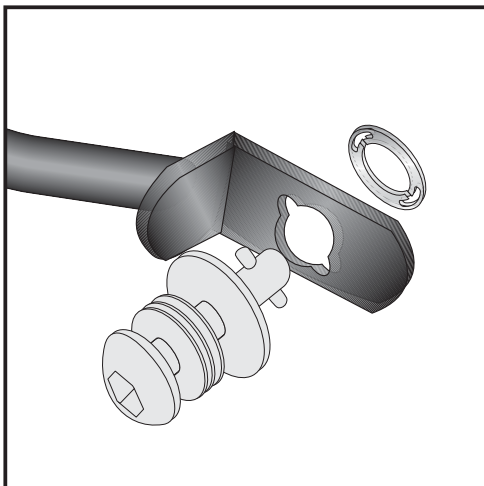

9 Fastening of Lock it screws:

The Lock it screws will be fixed at the carriers left and right with lock washers.

You have to do it only once - the screws and lock washers remain at the carriers.

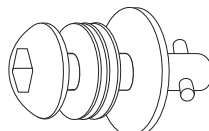

6x



Side carrier
YAMAHA FZ 1 Fazer from 2006

Item - No.:
650.4522.00 01 black



Assembling instructions

Side cases
Top cases
luggage frames
Lock it system
Softbags
Aluminium luggage
Leather luggage
Protection bars
Center stands
Chopper parts
Quad parts
Accessories

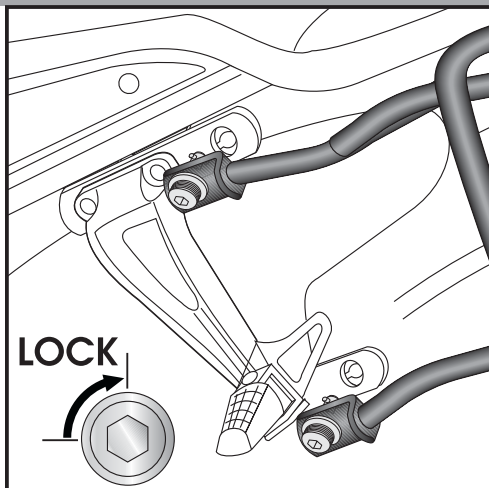

10

Fastening of carrier :

The carriers will now be fixed to the adapter with Lock it -screws

Attention !

Don't overturn the Lock it screw !

Rotate slowly one quarter of a turn until screw engages.

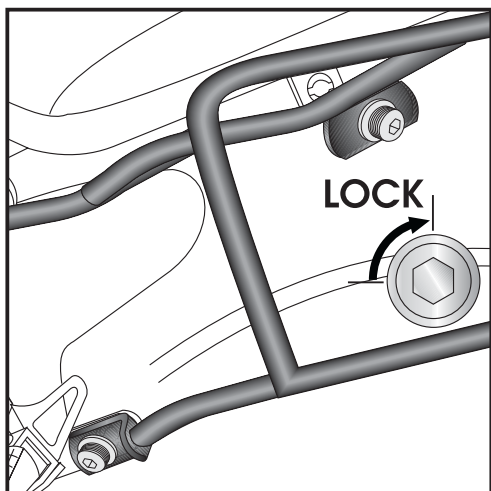

11

Fastening of carrier :

The carriers will now be fixed to the adapter with Lock it -screws

Attention !

Don't overturn the Lock it screw !

Rotate slowly one quarter of a turn until screw engages.

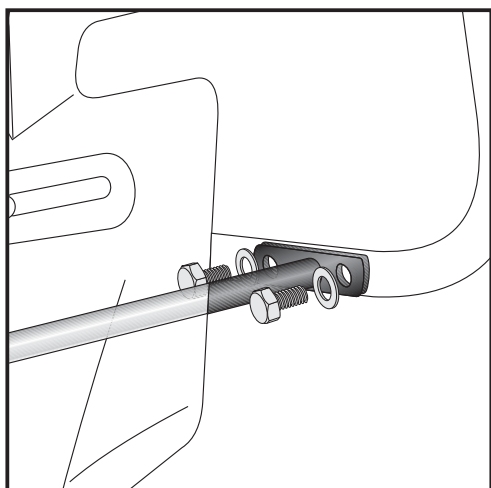

12

Fastening of the bracing bow:

Inside the fender with hexagon bolt M 6 x 12 and washers $\varnothing 6,4$.

Use the threads at the inner side of the side carriers.

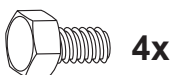

4x



4x

Side carrier
YAMAHA FZ 1 Fazer from 2006

Item - No.:
650.4522.00 01 black



Assembling instructions

Side cases
Top cases
luggage frames
Lock it system
Softbags
Aluminium luggage
Leather luggage
Protection bars
Center stands
Chopper parts
Quad parts
Accessories

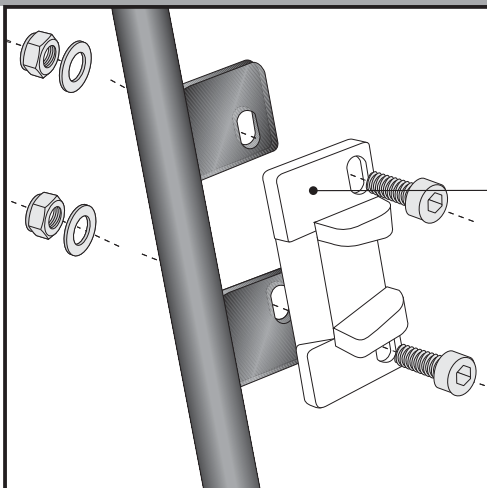

13 Hint: assembling side cases

Fastening of adapter to hook in the fixing lock

Hint :

The adapters are enclosed with the side cases.
They are not included in the side carrier set.

The necessary screws for mounting the metal adapter on the carrier are part of this set.

(Filister headscrew M6 x 16, washer ø6,4 and self lock nut M6).

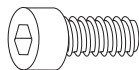

each 4x



Control all screw connections after the assembling for tightness!
Please notice our enclosed service information.

Also available:
501.420 01 01 Engine guard black



Hepco & Becker GmbH
An der Steinmauer 6
D-66955 Pirmasens
Germany

Tel.: +49 6331 - 1453 - 100
Fax: +49 6331 - 1453 - 120
eMail: vertrieb@hepco-becker.de
www.hepco-becker.de