

Kofferträger

HONDA CBF 1000 F

Art.Nr.:650.957 00 01 schwarz



Seitenkoffer

Topcases

Gepäckträger

Lock it System

Softbags

Aluminiumkoffer

Lederkoffer

Schutzbügel

Hauptständer

Chopper-Parts

Quad-Parts

Accessoires



Montageanleitung

Der Bausatz umfasst die folgenden Teile:

Stück	Bestellnr.	Bezeichnung	Stück	Bestellnr.	Bezeichnung
1	700006744	Kofferträger links lock it	4	150.911	Linsenkopfschrauben M 6 x 16
1	700006743	Kofferträger rechts lock it	4	150.838	Sechskantschrauben M 6 x 16
1	700006745	Versteifungsbügel	2	150.714	Linsenkopfschrauben M 6 x 40
1	700006746	Adapterlasche vorne links lock it	1	150.729	Linsenkopfschrauben M 8 x 55
1	700006747	Adapterlasche vorne rechts lock it	12	150.809	U-Scheiben ø 6,4 mm
1	700006748	Adapterwinkel oben links lock it	2	150.810	U-Scheiben ø 8,4 mm
1	700006749	Adapterwinkel oben rechts lock it	2	150.800	selbstsichernde Muttern M 8
4	150.792	Inbusschrauben M 8 x 70	6	150.799	selbstsichernde Muttern M 6
1	150.969	Linsenkopfschrauben M 8 x 60	4	151.070	Lock it Systemschrauben (Linsenkopf)
3	151.045	Karoseriescheibe ø30 x ø10,5 x 2,5 mm	4	151.071	Sicherungscheiben
4	151.298	Aludistanzen ø18 x ø11 x 26 mm			
1	150.707	Aludistanz ø23 x ø9 x 28 mm			

Die hinteren Blinker verbleiben in der Originalposition.

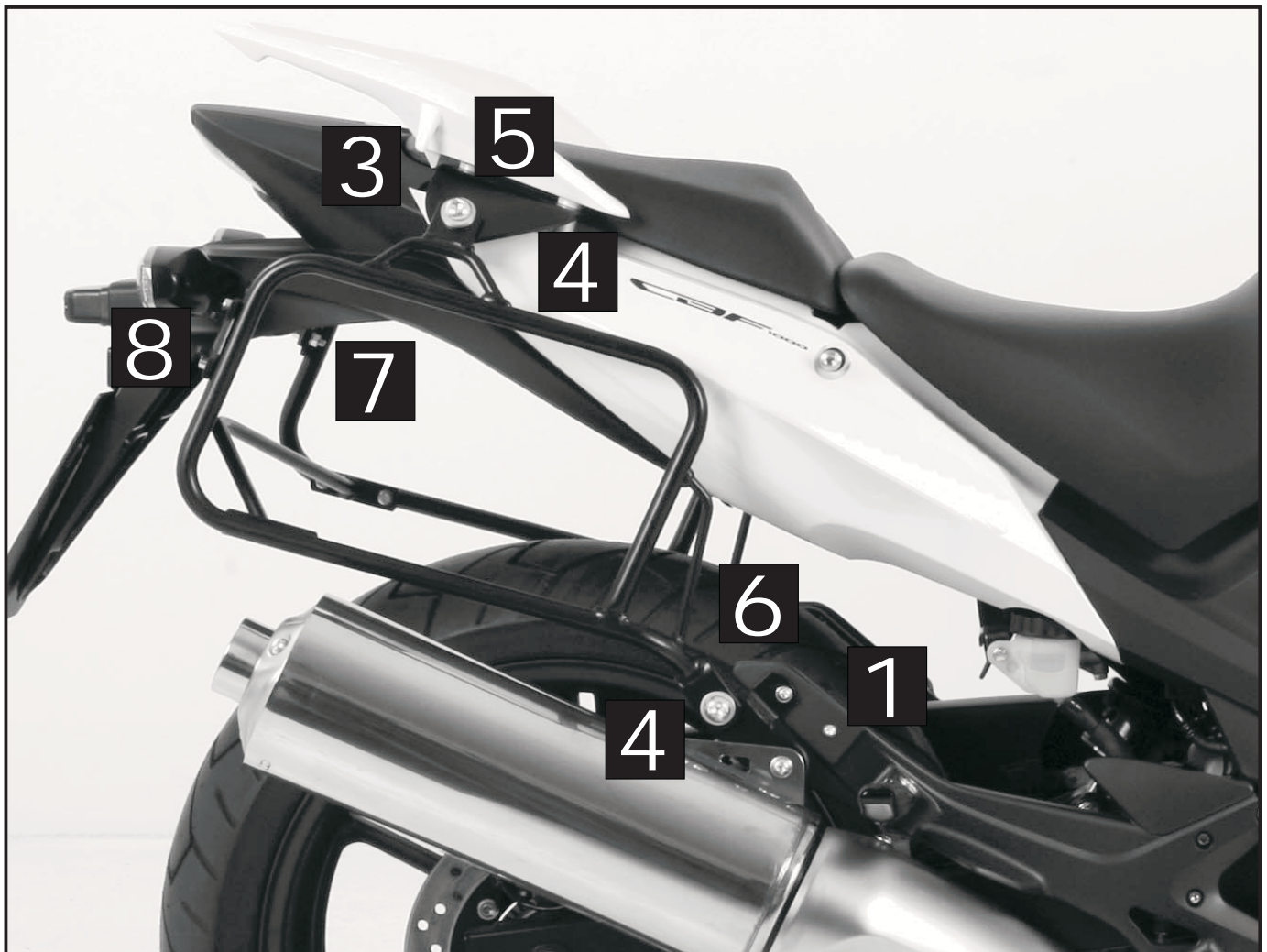



- Seitenkoffer
- Topcases
- Gepäckträger
- Lock it System
- Softbags
- Aluminiumkoffer
- Lederkoffer
- Schutzbügel
- Hauptständer
- Chopper-Parts
- Quad-Parts
- Accessoires

Montage

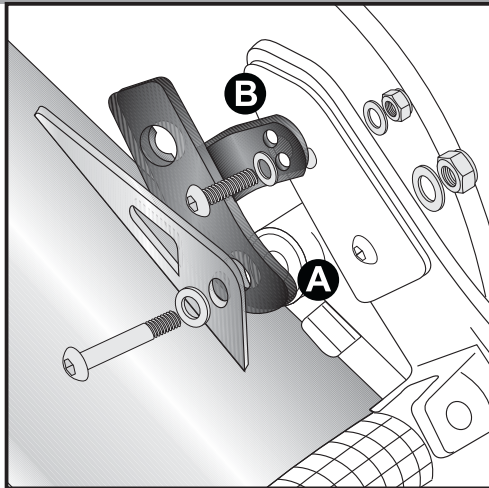

1

Befestigung der Adapterlaschen lock it vorne unten rechts:

A Die Verschraubung erfolgt an der Auspufftopaufhängung. Die Adapterlasche wird zwischen Halterung und Auspuff geschoben und mit den Linsenkopfschrauben \varnothing M 8 x 60, U-Scheiben \varnothing 8,4 und selbstsichernden Muttern M 8 verschraubt. Die Originalkaroseriescheiben entfallen.

B Eine zusätzliche Befestigung erfolgt an der Verschraubung des Vibrationsdämpfers mit Linsenkopfschrauben M 6 x 40 nebst U-Scheiben \varnothing 6,4 und selbstsichernden Muttern M 6.

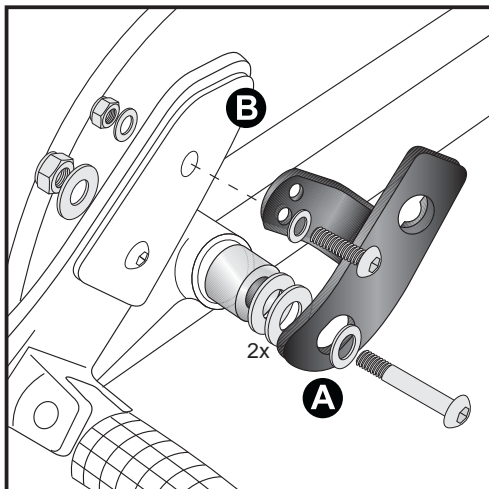
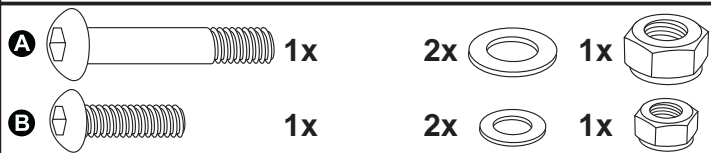

2

Montage der Adapterlaschen lock it vorne unten links:

A Am großen Befestigungsauge hinter der Soziusfußraste. In dieses die Aludistanz \varnothing 23,3 x \varnothing 9 x 28 mm einsetzen. Außen 2 Karoseriescheiben \varnothing 30 x \varnothing 10,5 x 2,5 mm, davor die Adapterlasche montieren. Zum Verschrauben die Linsenkopfschraube M 8 x 55, U-Scheibe und auf der Innenseite der Aludistanz 1 Karoseriescheibe \varnothing 30 x \varnothing 10,5 x 2,5 mm und eine selbstsichernde Mutter M8 verwenden.

B Eine zusätzliche Befestigung erfolgt an der Verschraubung des Vibrationsdämpfers mit Linsenkopfschrauben M 6 x 40 nebst U-Scheiben \varnothing 6,4 und selbstsichernden Muttern M 6.

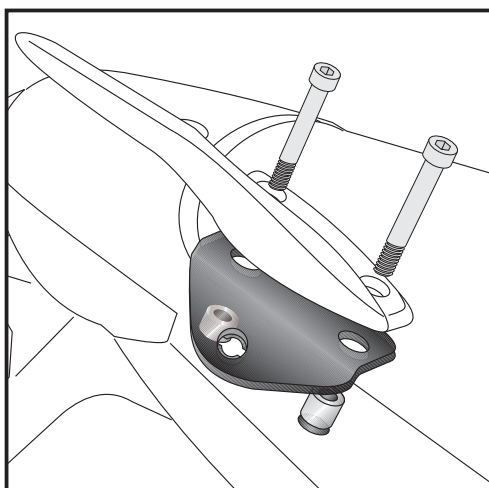
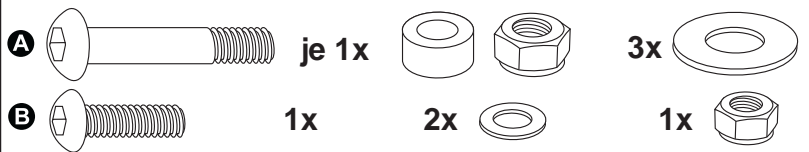

3

Befestigung der Adapterwinkel lock it links und rechts:

Die Original - Haltegriffe demontieren. In die frei gewordenen Bohrungen die Aludistanzen \varnothing 18 x \varnothing 11 x 26 mm einsetzen. Darüber die Adapterwinkel links und rechts sowie die Original - Haltegriffe fügen und mit den Inbusschrauben M 8 x 70 verschrauben.



Kofferträger

HONDA CBF 1000 F

Art.Nr.:650.957 00 01 schwarz



Montage

Seitenkoffer

Topcases

Gepäckträger

Lock it System

Softbags

Aluminiumkoffer

Lederkoffer

Schutzbügel

Hauptständer

Chopper-Parts

Quad-Parts

Accessoires

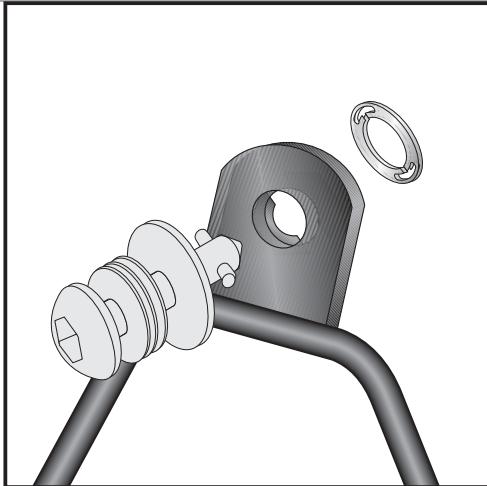

4

Montage der Lock it System-Schrauben:

An den Kofferträgern links / rechts werden die Lock it System-Schrauben an den Befestigungslaschen mittels der Sicherungsscheibe montiert. Die Scheiben und Lock it System-Schrauben verbleiben bei Demontage an den Befestigungspunkten der Kofferträger.

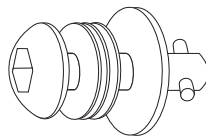

4x

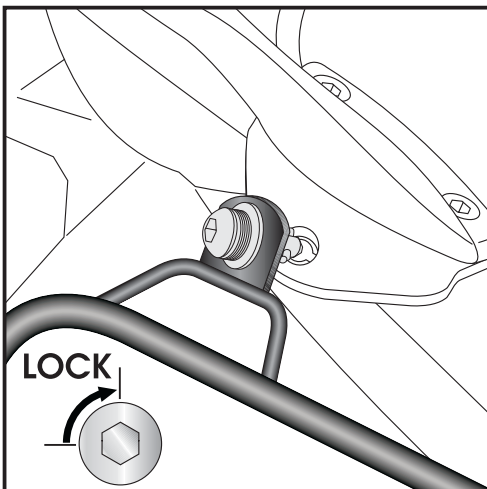

5

Montage der Kofferträger oben:

Die so vorbereiteten Kofferträger werden an den Adapterwinkeln mittels der Lock it System-Schrauben befestigt.

ACHTUNG:

Lock it System-Schrauben nicht überdrehen !
Langsam drehen (Viertelumdrehung) bis die Schraube fühlbar einrastet und am Anschlag anliegt.

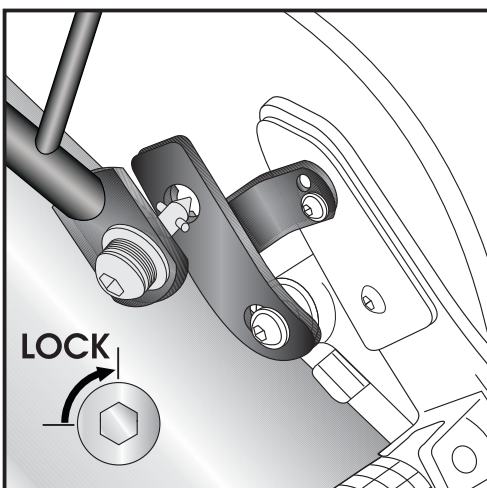

6

Montage der Kofferträger unten:

Die so vorbereiteten Kofferträger werden an der Adapterlasche mittels der Lock it System-Schrauben befestigt.

ACHTUNG:

Lock it System-Schrauben nicht überdrehen !
Langsam drehen (Viertelumdrehung) bis die Schraube fühlbar einrastet und am Anschlag anliegt.

Packende Ideen

3

Kofferträger

HONDA CBF 1000 F

Art.Nr.:650.957 00 01 schwarz



Montage

Seitenkoffer
Topcases
Gepäckträger
Lock it System
Softbags
Aluminiumkoffer
Lederkoffer
Schutzbügel
Hauptständer
Chopper-Parts
Quad-Parts
Accessoires

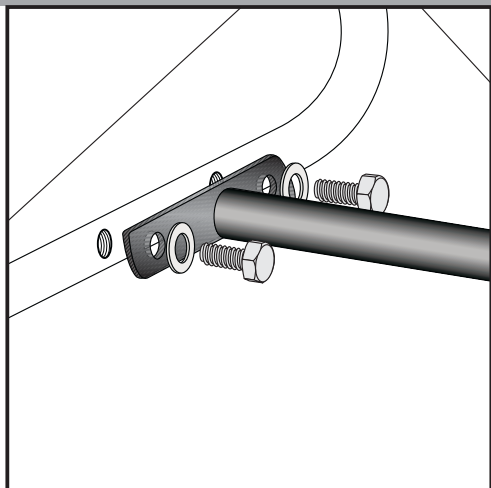

7

Befestigung des Versteifungsbügel:
Dieser verläuft innerhalb des Kotflügels.
Die Verschraubung erfolgt an der Innenseite der Kofferträger in dort vorhandenen Gewindebohrungen mit den Sechskantschrauben M 6 x 16 nebst U-Scheiben $\varnothing 6,4$.

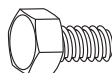

je 4x

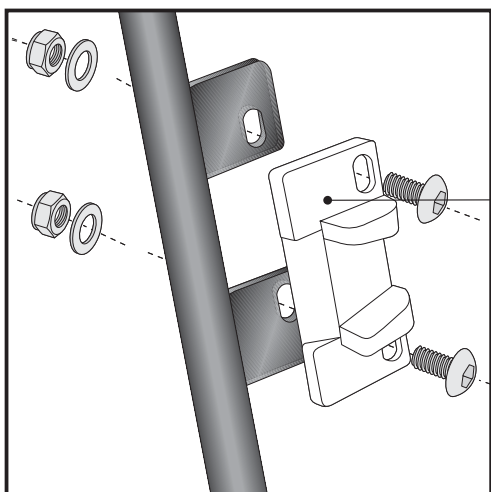

8

Hinweise zur Koffermontage

Montage des Metalladapters zum Einhängen des Kofferhalteschlusses

HINWEIS :
die Metalladapter liegen den Koffern bei, nicht diesem Kofferträgerset.

Die notwendigen Schrauben zur Montage der Metalladapter am Kofferträger sind beigelegt (Linsenkopfschrauben M6 x 16, U-Scheiben $\varnothing 6,4$, selbstsichernde Muttern M6).

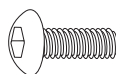

je 4x



Anzugsmomente des Motorradherstellers beachten!
Nach der Montage alle Verschraubungen auf festen Sitz kontrollieren!
Bitte beachten Sie unsere beigelegten Serviceinformationen.

Als weiteres Zubehör lieferbar:

650.957 01 01 Gepäckbrücke

501.957 00 01 Motorschutzbügel

630.957 C-Bow Softtaschenhalter



Hepco & Becker GmbH
An der Steinmauer 6
D-66955 Pirmasens

Tel.: 06331 - 1453 - 100
Fax: 06331 - 1453 - 120
eMail: vertrieb@hepco-becker.de
www.hepco-becker.de

Side carrier
HONDA CBF 1000 F

Item - No.: 650.957 00 01 black



Assembling instructions

Side cases

Top cases

luggage frames

Lock it system

Soffbags

Aluminium luggage

Leather luggage

Protection bars

Center stands

Chopper parts

Quad parts

Accessories



The kit includes the following parts:

Quant	item no.	description	Quant	item no.	description
1	700006744	carrier left side lock it	4	150.911	fillister headscrew M 6 x 16
1	700006743	carrier right side lock it	4	150.838	hexagon bolt M 6 x 16
1	700006745	bracing bow	2	150.714	fillister headscrew M 6 x 40
1	700006746	mounting strut left side	1	150.729	fillister headscrew M 8 x 55
1	700006747	mounting strut right side	12	150.809	washer ø 6,4 mm
1	700006748	mounting bracket left side	2	150.810	washer ø 8,4 mm
1	700006749	mounting bracket right side	2	150.800	self-lock nut M 8
4	150.792	allen screw M 8 x 70	6	150.799	self-lock nut M 6
1	150.969	fillister headscrew M 8 x 60	4	151.070	lock it screws
3	151.045	body washerø30 x ø10,5 x 2,5 mm	4	151.071	lock washer
4	151.298	alu spacer ø18 x ø11 x 26 mm			
1	150.707	alu spacer ø23 x ø9 x 28 mm			

The raer blinker remain in their original position.

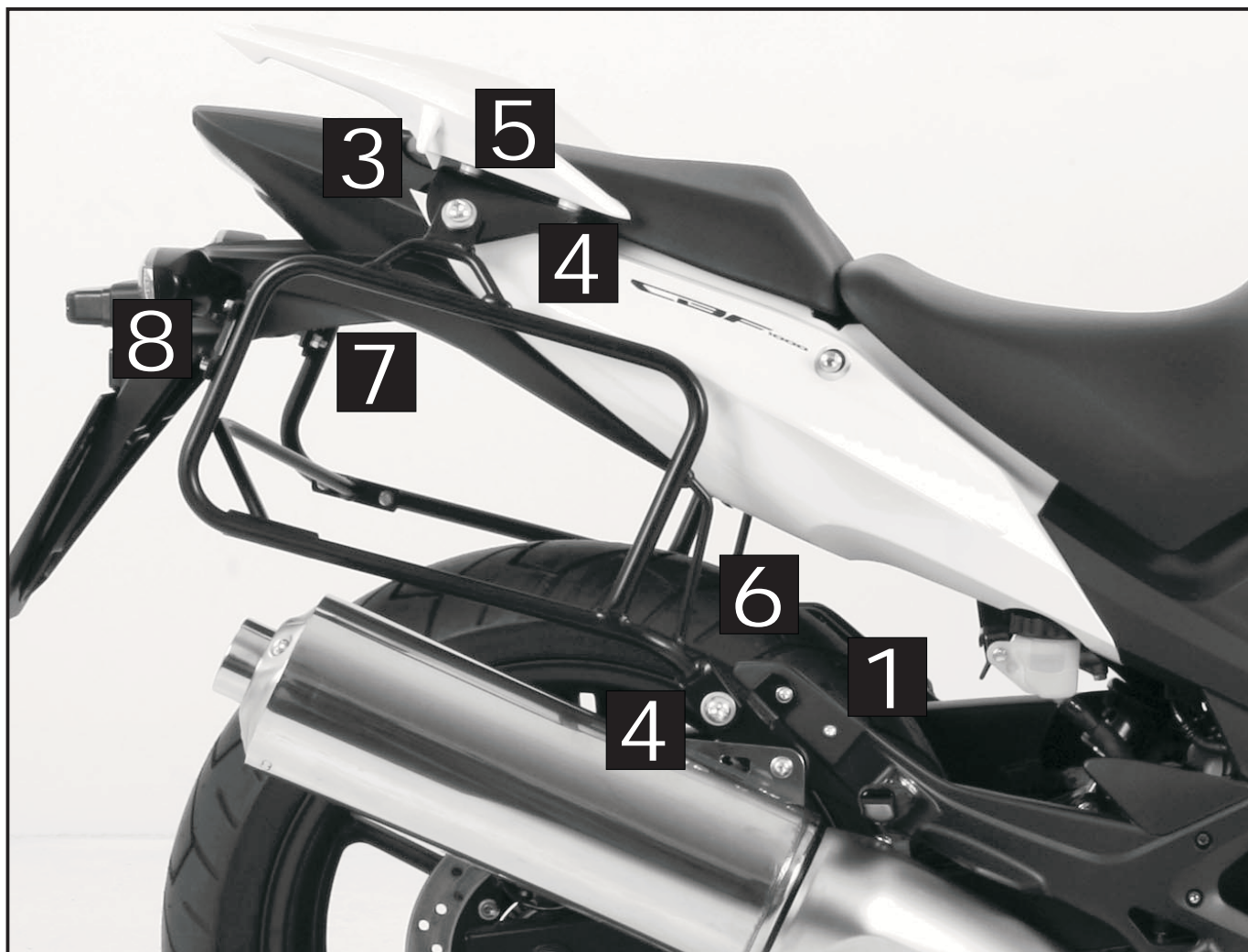

Side carrier
HONDA CBF 1000 F

Item - No.: 650.957 00 01 black



Assembling instructions

- Side cases
- Top cases
- Luggage frames
- Lock it system
- Softbags
- Aluminium luggage
- Leather luggage
- Protection bars
- Center stands
- Chopper parts
- Quad parts
- Accessories

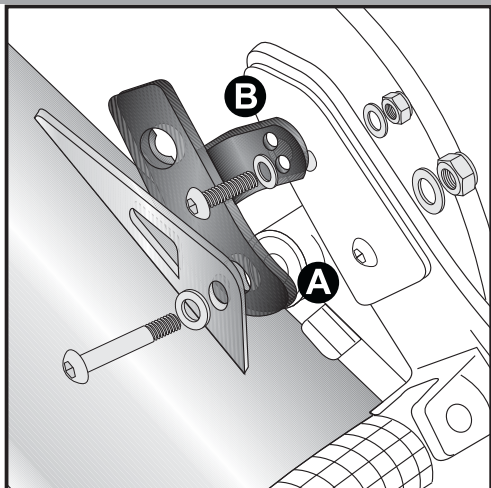

1

Fastening of the mounting strut lock it front right:

A Use the fixing of the exhaust muffler. Place mounting strut between holder and exhaust and fix it with fillister headscrew M 8 x 60, washer \varnothing 8,4 and self-lock nut M 8. The original body washers are obsolete.

B Another fixing is needed at point B with fillister headscrew M 6 x 40 and washer \varnothing 6,4 and self-lock nut M 6.

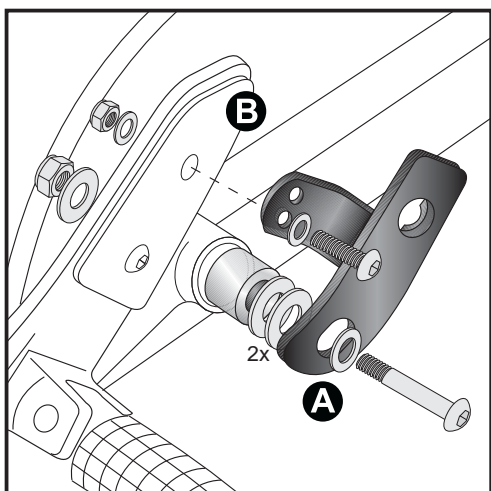
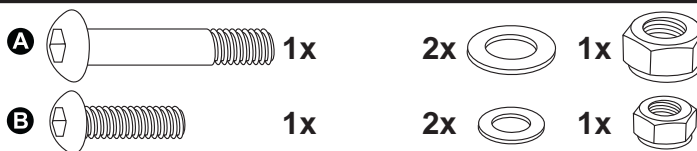

2

Fastening of the mounting strut lock it front left:

A Behind the mounting strut, sandwich alu spacer \varnothing 23,3 x \varnothing 9 x 28 mm and 2 body washer \varnothing 30 x \varnothing 10,5 x 2,5 mm. To fix, use fillister headscrew M 8 x 55, washer \varnothing 8,4. At the inside use a body washer \varnothing 30 x \varnothing 10,5 x 2,5 mm and self-lock nut M8.

B Another fixing is needed at point B with fillister headscrew M 6 x 40, washers \varnothing 6,4 and self-lock nut M 6.

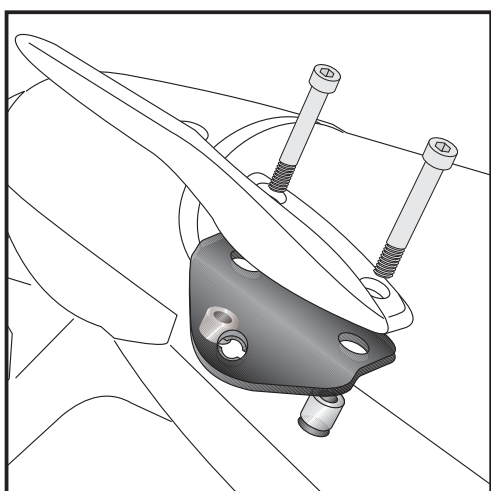
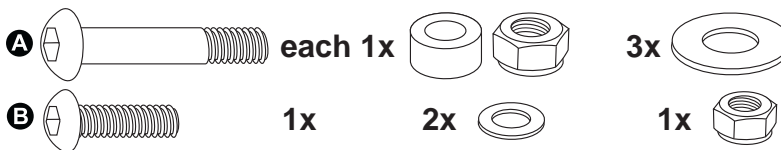

3

Fastening of the mounting bracket lock it left + right:

Unmount handrails.
Sandwich alu spacer \varnothing 18 x \varnothing 11 x 26 mm.
Fix the mounting brackets together with the handrail.
Use allen screw M 8 x 70.



Luggage ideas.

Side carrier
HONDA CBF 1000 F

Item - No.: 650.957 00 01 black



Assembling instructions

Side cases
Top cases
luggage frames
Lock it system
Softbags
Aluminium luggage
Leather luggage
Protection bars
Center stands
Chopper parts
Quad parts
Accessories

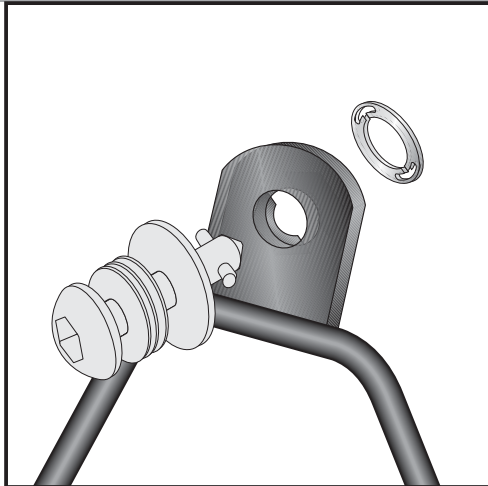

4

Fastening of Lock it screws:

The Lock it screws will be fixed at the carriers left and right with lock washers.

You have to do it only once - the screws and lock washers remain at the carriers.

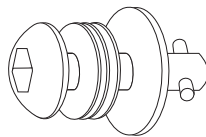

4x

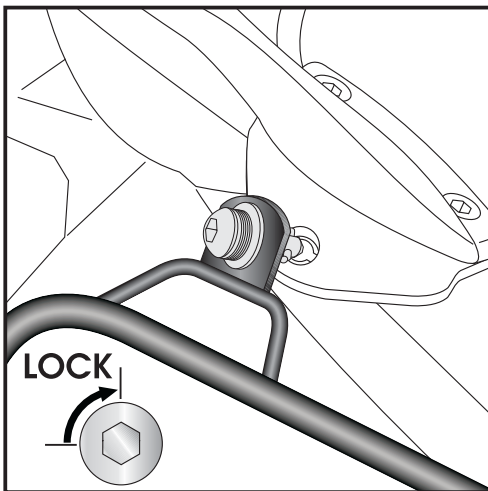

5

Fastening of carrier top:

The carriers will now be fixed to the adapter with Lock it -screws

Attention !

Don't overturn the Lock it screw !

Rotate slowly one quarter of a turn until screw engages.

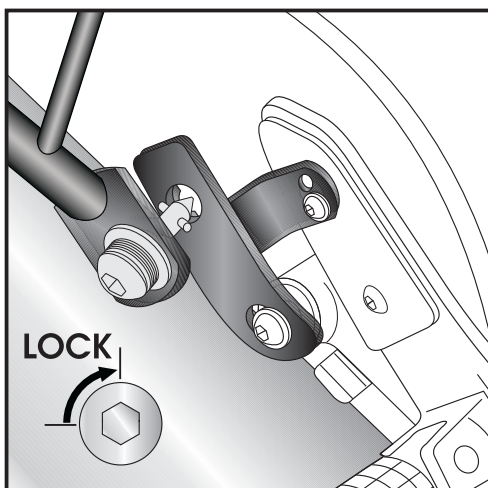

6

Fastening of carrier down:

The carriers will now be fixed to the adapter with Lock it -screws

Attention !

Don't overturn the Lock it screw !

Rotate slowly one quarter of a turn until screw engages.

Luggage ideas.

3

Side carrier
HONDA CBF 1000 F

Item - No.: 650.957 00 01 black



Assembling instructions

Side cases
Top cases
luggage frames
Lock it system
Softbags
Aluminium luggage
Leather luggage
Protection bars
Center stands
Chopper parts
Quad parts
Accessories

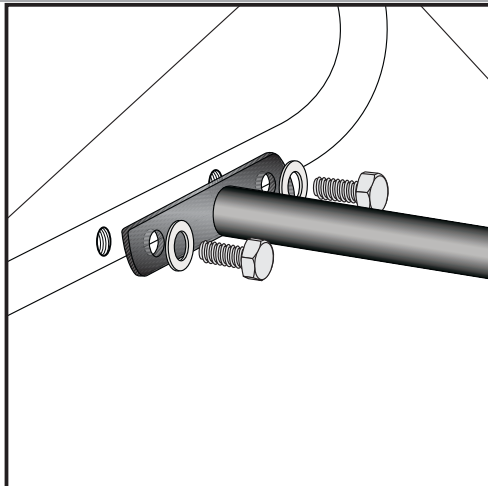

7

Fastening of the bracing bow:
with hexagon bolt M 6 x 18 and washer $\varnothing 6,4$.
Use the threads at the inner side of the side carriers.

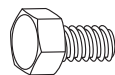

each 4x

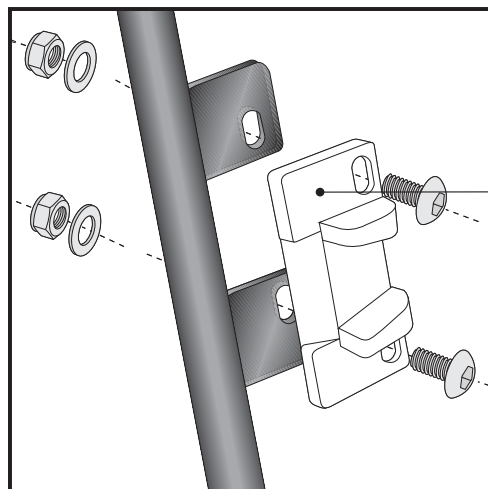

8

Hint: assembling side cases

Fastening of adapter to hook in the fixing lock

Hint :

The adapters are enclosed with the side cases.
They are not included in the side carrier set.

The necessary screws for mounting the metal adapter on the carrier
are part of this set.
(Filister headscrew M6 x 16, washer $\varnothing 6,4$ and self lock nut M6).

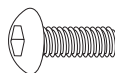

each 4x



Control all screw connections after the assembling for tightness!
Please notice our enclosed service information.

Also available:

650.957 01 01 Rear rack black
501.957 00 01 Engine guard
630.957 C-Bow holder for softbags



Hepco & Becker GmbH
An der Steinmauer 6

D-66955 Pirmasens

Tel.: +49 (0)6331 - 1453 - 100
Fax: +49 (0)6331 - 1453 - 120
eMail: vertrieb@hepco-becker.de
www.hepco-becker.de