



FITTING INSTRUCTIONS FOR LP0186BK LICENCE PLATE BRACKET
KAWASAKI VULCAN S '15-



THIS KIT CONTAINS THE ITEMS PICTURED AND LABELLED BELOW.
DO NOT PROCEED UNTIL YOU ARE SURE ALL PARTS ARE PRESENT.

Please note that the way the kit is packed does not necessarily represent the way of mounting to the bike.

THE PARTS SHOWN MAY BE REPRESENTATIVE ONLY (FOR CLARITY OF INSTRUCTIONS ONLY).

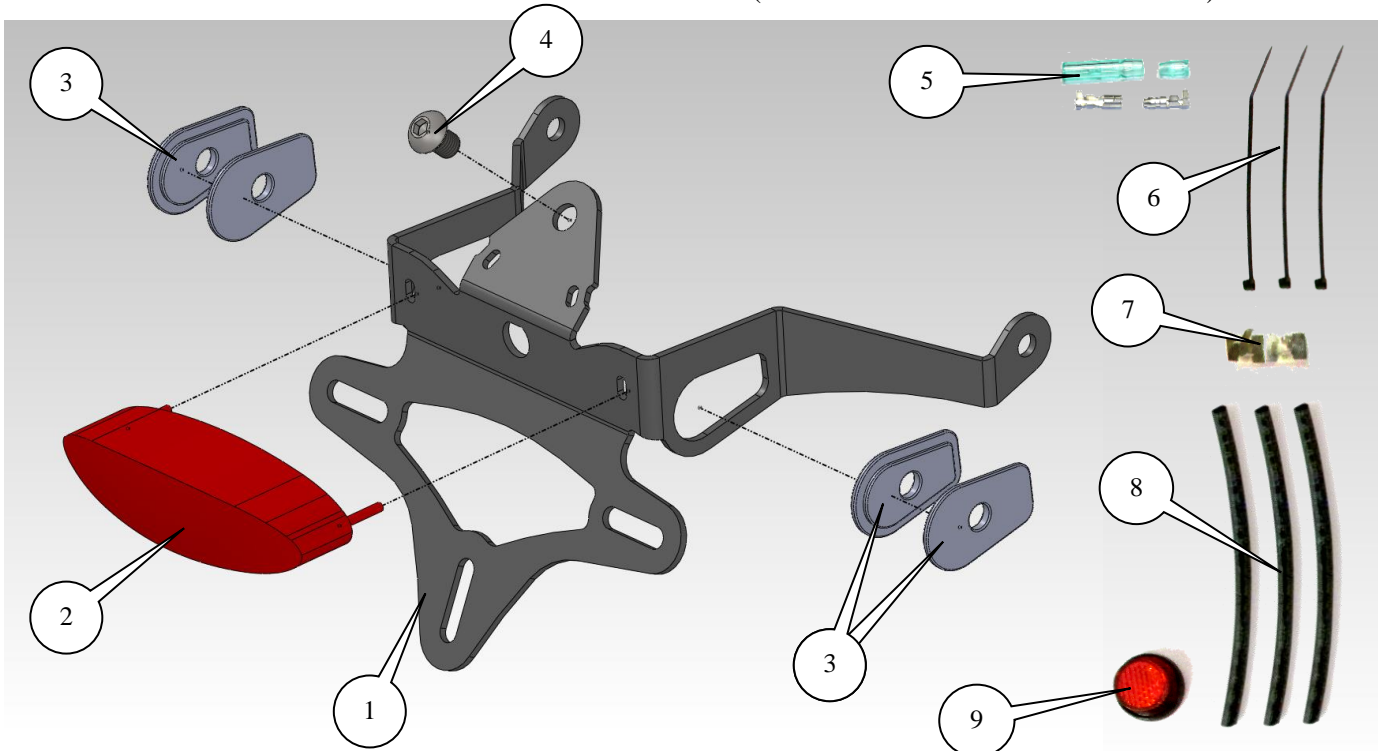



LEGEND

- ITEM 1 = MAIN BRACKET (TB0186) (x1).
- ITEM 2 = LA0003 TAIL LIGHT (x1).
- ITEM 3 = INDICATOR ADAPTORS (I0026) (x4).
- ITEM 4 = M8 x 12mm LONG BUTTON HEAD BOLT (x1).
- ITEM 5 = BULLET CONNECTORS (CON0004) (x4).
- ITEM 6 = 2.5mm CABLE TIES (x3).
- ITEM 7 = SELF ADHESIVE CABLE CLIPS (x2).
- ITEM 8 = 150mm LENGTH OF HEATSHRINK (x3).
- ITEM 9 = REFLECTOR (x1).

Please note that in cases where kits are packed with rubber washers holding the components onto the bolt – *the rubber washers should be thrown away!*

TOOLS REQUIRED

- Set of metric Allen keys to include 4, 5 & 6mm A/F size.
 - 6, 10 & 12mm spanners or sockets.
 - Phillips screwdriver.
 - Cable cutters.

MAXIMUM TORQUE SETTINGS

- M4 Bolt = 8 Nm
- M5 Bolt = 12 Nm
- M6 Bolt = 15 Nm
- M8 Bolt = 20 Nm



Picture 1



Picture 2



Picture 3



Picture 4

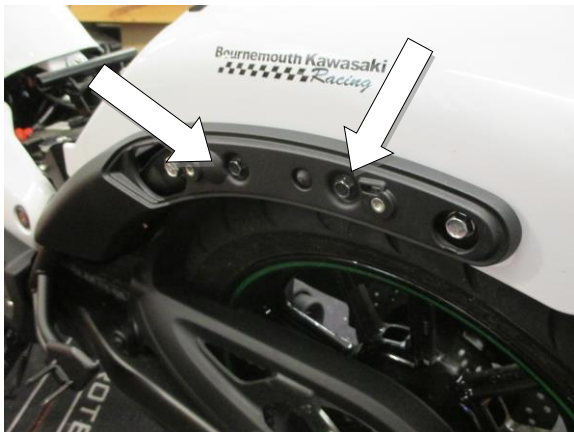

Picture 5



Picture 6



Picture 7

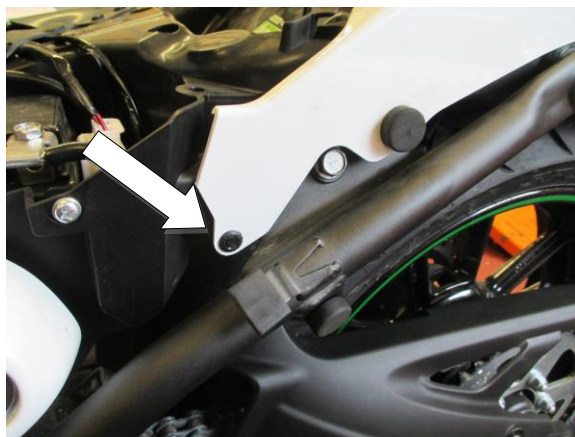

Picture 8



Picture 9



Picture 10



Picture 11



Picture 12



Picture 13



Picture 14



Picture 15



Picture 16



Picture 17



Picture 18



Picture 19



Picture 20



Picture 21



Picture 22



Picture 23



Picture 24



Picture 25



Picture 26



Picture 27



Picture 28



Picture 29

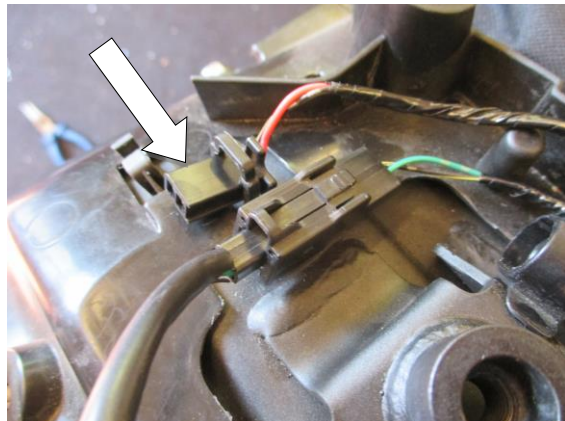

Picture 30



Picture 31



Picture 32



Picture 33



Picture 34



Picture 35



Picture 36

FITTING INSTRUCTIONS

- To fit the R&G tail tidy, remove the pillion seat by removing the bolt as shown in picture 1.
- Remove the bolt that secures the seat in place along with the bracket for the pillion seat, as shown in picture 2.
- Remove the seat as shown in picture 3.
- Remove the two bolts that secure the plastic cover in place on both sides of the bike, as arrowed in picture 4.
- With these panels off, access can be gained to the two bolts that secure the inner plastic in place, as arrowed in picture 5. Remove these two bolts, then slide the plastic panel forwards and remove from the bike. Repeat this on both sides of the bike.
- With these panels off, remove the two 12mm hex head bolts that secure the mounting plate in place and remove from the bike, as shown in picture 6. Repeat this on the other side of the bike.
- Remove the two bolts that secure the mudguard in place at the front, as arrowed in picture 7.
- At the bottom front edge of the mudguard, there is a push rivet locating the part. Remove this push rivet on both sides of the bike, as shown in picture 8.



- The plastic mudguard can now be removed from the bike, as shown in picture 9. *The rear of the mudguard will need to be spread out slightly to clear the bosses on the frame during removal.*
- Disconnect the four wiring connectors, as shown in picture 10.
- Remove the bolt securing the side of the OEM licence plate hanger on both sides of the bike, as shown in picture 11.
- Remove the two bolts on the rear of the licence plate, as shown in picture 12.
- The OEM licence plate hanger can now be removed from the bike, as shown in picture 13.
- Remove the three bolts that secure the rear metal bracket for the OEM licence plate hanger, as shown in picture 14 & 15.
- Take the licence plate bracket (item 1 – TB0186) and fit the R&G tail light (item 2 – LA0003) to the bracket, as shown in picture 16. Fit one length of heatshrink to the wires and tighten the nuts on the rear, as shown in picture 17.

If fitting R&G Mini Indicators

- To fit the R&G Mini Indicators, the wiring will need to be cut and shut in order to connect the indicators. To do this, cut through the rear indicator wires about 50mm from the indicator. Strip the ends of the two wires on the connector end and fit the bullet connectors supplied (item 5 – CON0004) to the two wires for the indicators in order to match them to the bullet connectors on the R&G Mini Indicators.
- *If fitting R&G Aero Indicators with LED's the yellow wire on the Aero Indicators connects with the green wire on both indicators and the black/white wire on the Mini Indicators connects with the black/yellow wire on the OEM wiring. 1x set of RGR0001 resistors (available separately) are required to achieve the correct flash rate.*
- *If fitting R&G Mini Indicators with bulbs, the black wire on the Mini Indicators connects with the green wire on both indicators and the black/white wire on the Mini Indicators connects with the black/yellow wire on the OEM wiring.*
- *If fitting R&G Mini Indicators with LED's, the black/white wire on the Mini Indicators connects with the green wire on both indicators and the black wire on the Mini Indicators connects with the black/yellow wire on the OEM wiring. 1x set of RGR0001 resistors (available separately) are required to achieve the correct flash rate.*
- On the wiring of each indicator, feed two of the indicator adaptors (item 3 – I0026) so that the sides with the bosses sit next to each other, as shown in picture 18.
- Fit one length of heatshrink supplied (item 8) to protect the indicator wiring before feeding the wires through the indicator mounting hole on the tail tidy, as shown in picture 19. Feed the flanged nut over the wiring and tighten onto the threaded boss of the indicator.
- Repeat the above process for the remaining indicator.

If fitting OEM Indicators

- To remove the OEM indicators, remove the Phillips screw from the rear of the indicator mount and this will allow the mounting plate to come off, as shown in picture 21.
- Remove the other metal plate that sits within the indicator rubber mount, and feed this off of the wiring. The indicator can now be twisted so that the rubber mount detaches from the plastic and can be removed from the OEM licence plate hanger, as shown in pictures 22 & 23.
- To fit the OEM indicators to the R&G Tail Tidy, re-fit the indicator and mounting rubber in the same way that it was removed to the indicator mounting hole on the main bracket, as shown in picture 24.
- Re-fit the metal plate into the rubber, along with the outer metal plate and Phillips screw as originally removed & shown in picture 25.

R&G Racing

Unit 1, Shelley's Lane, East Worldham, Alton, Hampshire, GU34 3AQ

Tel: +44 (0)1420 89007 Fax: +44 (0)1420 87301 www.rg-racing.com Email: info@rg-racing.com



- Use the cable ties supplied to neatly route the tail light and indicator wiring to the tail tidy bracket via the two slots, as shown in picture 26.
- The tail tidy assembly can now be fitted to the bike. To do this, re-use the two M6 bolts and bolt the sides of the tail tidy to the mounting holes on the motorcycle frame on both sides, as shown in picture 27.
- Take the M8 x 12mm long button head bolt (item 4) and fit it through the remaining central mounting hole on the tail tidy and tighten into the threaded hole on the motorcycle, as shown in picture 28.
- To connect the new tail light to the main loom, the wires need to be “cut and shut”. To do this, cut the connector and a suitable length of wiring (as shown in picture 29) off the OEM light and fit bullet connectors to all three of the wires. Fit the opposite connectors to the tail light wiring and connect the wiring as follows: OEM red to yellow, OEM blue to red & OEM black/yellow to black.
- Reconnect all three connectors to the main loom on the bike and check for the correct operation of all lights at this stage (*please note that the fourth connector (arrowed in picture 30) is no longer required in use*).
- The rear mudguard can now be re-fitted to the bike using the reverse steps of how it was removed.
- Re-fit the mudguard, push rivets and two bolts as shown in pictures 31, 32 & 33.
- Re-fit the metal plates on both sides of the bike using the two bolts, as shown in picture 34.
- Re-fit the two plastic side panels on both sides of the bike using the original bolts, as shown in picture 35.
- Re-fit the two plastic cover panels on both sides of the bike using the original bolts, as shown in picture 36.
- Re-fit the seat and pillion seat using the original bolts.
- Ensure the tail tidy is securely mounted and all bolts are fully tightened.
- Re-fit the licence plate (it may require drilling).
- Depending on local laws, attach enclosed reflector in an appropriate location.
- Test the license plate illuminator and all lights before riding.

ISSUE 1 08/10/2015 (AR)

Digital copies of these instructions are available to download from www.rg-racing.com



**INSTRUCTIONS DE MONTAGE POUR LP0186BK SUPPORT DE PLAQUE
KAWASAKI VULCAN S '15-**



Assurez vous que toutes les pièces soient présentes avant de procéder au montage.

La façon dont le kit est emballé ne correspond pas forcément à la façon de monter les pièces sur la moto.

Les pièces présentées peuvent n'être que représentatives, afin de faciliter et clarifier les instructions de montage.

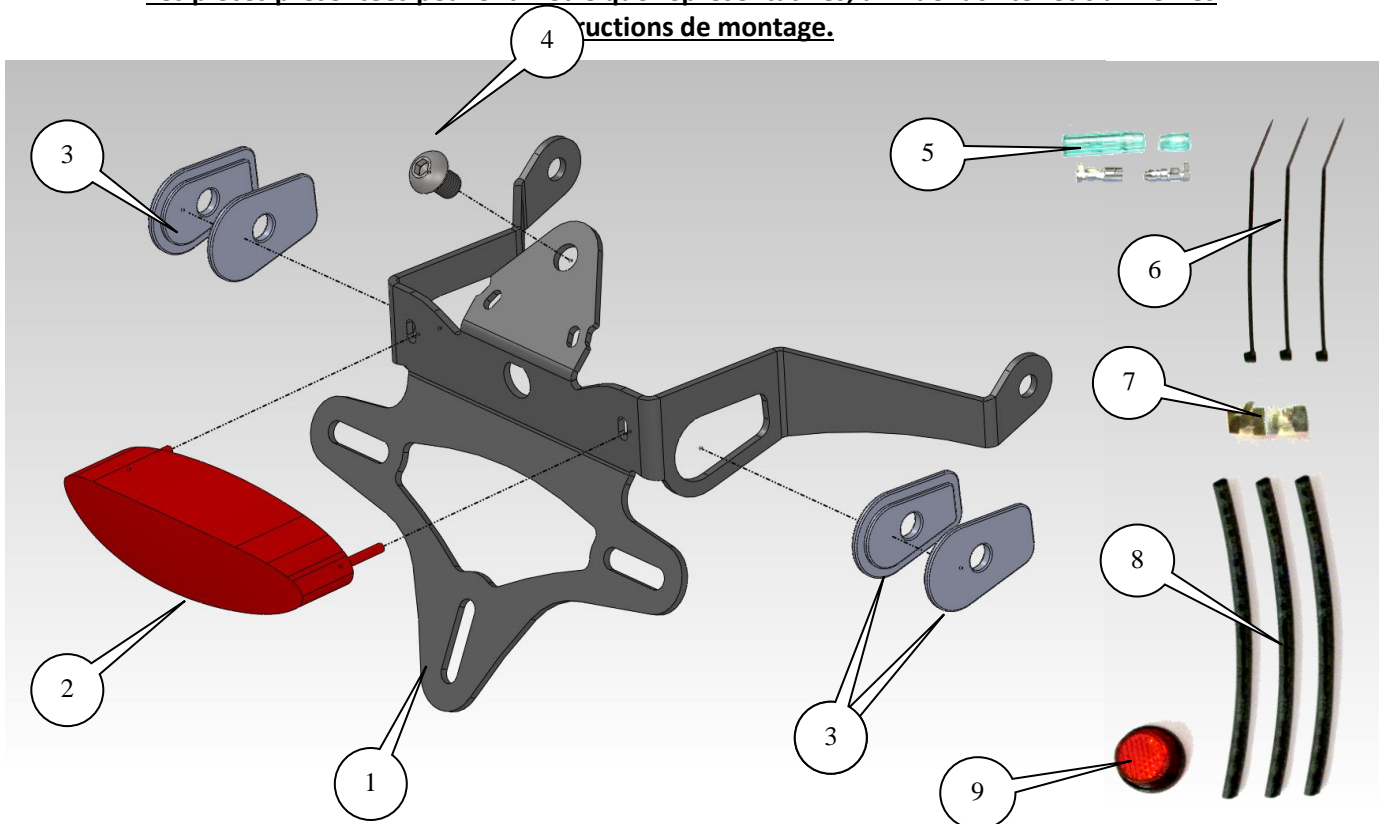



LEGENDE

- ARTICLE 1 = SUPPORT PRINCIPAL (TB0186) (x1).
- ARTICLE 2 = LA0003 FEU DE PLAQUE (x1).
- ARTICLE 3 = ADAPTATEURS CLIGNOTANTS (I0026) (x4).
- ARTICLE 4 = M8 x 12mm BOULON (x1).
- ARTICLE 5 = CONNECTEURS (CON0004) (x4).
- ARTICLE 6 = 2.5mm COLLIERS DE SERRAGE (x3).
- ARTICLE 7 = CLIPS AUTOCOLLANTS (x2).
- ARTICLE 8 = 150mm MANCHON THERMORETRACTABLE (x3).
- ARTICLE 9 = REFLECTEUR (x1).

Notez que si les kits sont emballés avec des rondelles en caoutchouc servant à tenir les composants, *ces rondelles doivent être jetées.*

OUTILS REQUIS

- Clés Allen 4, 5 & 6mm.
- Clés 6, 10 & 12mm.
- Tournevis cruciforme.
- Pince coupante.

COUPLES DE SERRAGE

- M4 Boulon = 8 Nm
- M5 Boulon = 12 Nm
- M6 Boulon = 15 Nm
- M8 Boulon = 20 Nm



Photo 1



Photo 2



Photo 3



Photo 4

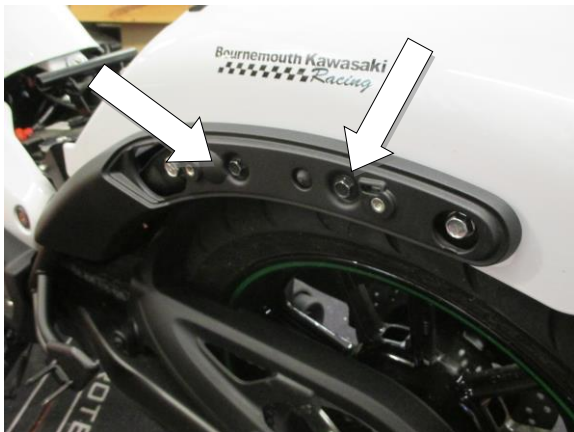

Photo 5



Photo 6



Photo 7

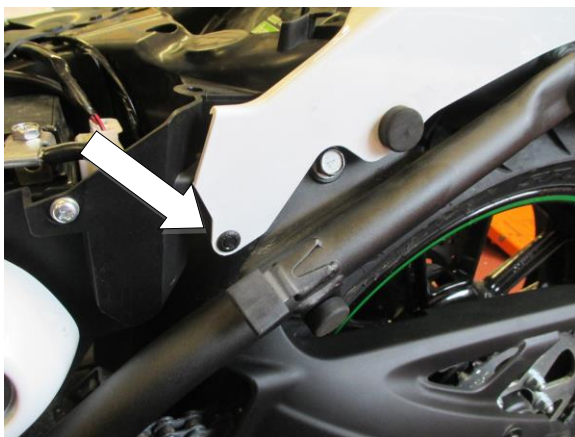

Photo 8



Photo 9



Photo 10



Photo 11



Photo 12



Photo 13



Photo 14



Photo 15



Photo 16



Photo 17



Photo 18



Photo 19



Photo 20



Photo 21



Photo 22



Photo 23



Photo 24



Photo 25



Photo 26



Photo 27



Photo 28



Photo 29

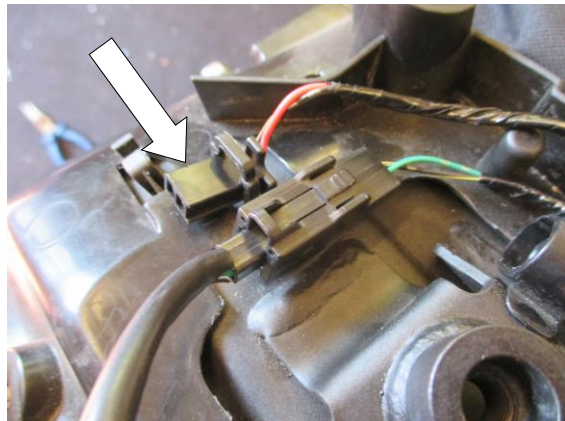

Photo 30



Photo 31



Photo 32



Photo 33



Photo 34



Photo 35



Photo 36

INSTRUCTIONS DE MONTAGE

- Enlever le siège passage en enlevant le boulon, voir photo 1.
- Enlever le boulon qui fixe le siège en place avec le support du siège passage, voir photo 2.
- Enlever le siège, voir photo 3.
- Enlever les 2 boulons qui fixent le cache plastique en place des 2 cotés de la moto, voir photo 4.
- Une fois ces caches enlevés, vous pouvez accéder aux 2 boulons qui fixent le plastique interne en place, voir photo 5. Enlever ces deux boulons, puis glissez le cache plastique vers l'avant avant de l'enlever de la moto. Répéter cette action de l'autre coté de la moto.
- Une fois ces caches enlevés, enlevez les 2 boulons 12mm qui fixent la plaque en place puis enlevez la de la moto, voir photo 6. Répéter cette action de l'autre coté de la moto.
- Enlever les 2 boulons qui fixent le garde boue en place à l'avant, voir photo 7.
- Sur le bord avant inférieur du garde boue, il y a un rivet plaçant la partie. Enlever ce rivet des 2 cotés de la moto, voir photo 8.
- Le garde boue peut à présent être enlevé de la moto, voir photo 9. L'arrière du garde boue devra être écarté pour libérer les patrons sur le cadre pendant le démontage.
- Déconnecter les 4 connecteurs de fils, voir photo 10.

R&G Racing

Unit 1, Shelley's Lane, East Worldham, Alton, Hampshire, GU34 3AQ

Tel: +44 (0)1420 89007 Fax: +44 (0)1420 87301 www.rg-racing.com Email: info@rg-racing.com



- Enlever le boulon qui fixe le bord du support de plaque d'origine des 2 cotés, voir photo 11.
- Enlever les 2 boulons à l'arrière de la plaque d'immatriculation, voir photo 12.
- Le support de plaque d'origine peut maintenant être enlevé de la moto, voir photo 13.
- Enlever les 3 boulons qui fixent le support arrière métallique pour le support de plaque d'origine, voir photo 14 & 15.
- Prendre le support de plaque (article 1 – TB0186) et montez les feu R&G (article 2 – LA0003) sur le support, voir photo 16. Appliquer un manchon thermo rétractable sur les fils puis serrer les écrous à l'arrière, voir photo 17.

Si vous Montez des mini clignotants R&G

- Pour monter des minis clignotants R&G, le fil devra être coupé puis fermé pour connecter les clignotants. Pour cela, coupez les fils de clignotants arrière à environ 50mm du clignotant. Dénudez les extrémités des 2 fils sur l'extrémité du connecteur et montez les connecteurs fournis (article 5 – CON0004) sur les 2 fils de clignotants pour les accorder aux connecteurs de mini clignotants R&G.
- *Si vous montez les clignotants latéraux R&G à LED, le fil jaune des clignotants LED se connectent avec le fil vert sur les 2 clignotants, et le fil noir / blanc des mini clignotants se connecte avec le fil noir / jaune sur le fil d'origine. Un set de résistances RGR0001 (disponible séparément) est nécessaire pour obtenir le bon éclairage.*
- *Si vous montez les mini clignotants à ampoule, le fil noir sur les mini clignotants se connecte avec le fil vert et le fil noir / blanc sur les mini clignotants se connecte avec le fil noir / jaune sur le fil d'origine.*
- *Si vous montez les mini clignotants R&G à LED, le fil noir / blanc des mini clignotants se connecte avec le fil vert sur les 2 clignotants et le fil noir sur les mini clignotants se connecte avec le fil noir / jaune sur le fil d'origine. Un set de résistances RGR0001 (disponible séparément) est nécessaire pour obtenir le bon éclairage.*
- Sur le fil de chaque clignotant, passez 2 des adaptateurs de clignotants (article 3 – I0026) de façon à ce que les cotés munis de patrons se placent l'un à coté de l'autre, voir photo 18.
- Appliquer un manchon thermo rétractable fourni (article 8) pour protéger le fil de clignotant avant de passer les fils dans le trou de fixation du clignotant sur le support de plaque, voir photo 19. Passer l'écrou sur le fil puis serrer sur le patron fileté du clignotant.
- Répéter le procédé ci-dessus pour le clignotant restant.

Si vous montez les clignotants d'origine

- Pour enlever les clignotants d'origine, enlever la vis située à l'arrière du support de clignotant, cela permettra à la plaque de fixation de se détacher, voir photo 21.
- Enlever l'autre plaque métallique placée sur le support clignotant en caoutchouc, puis passez la hors des fils. Le clignotant peut à présent être un peu tordu pour que le support de caoutchouc se détache du plastique et puisse être enlevé du support de plaque d'origine, voir photos 22 & 23.
- Pour monter les clignotants d'origine sur le support R&G, remonter le clignotant et le support en caoutchouc de la même façon qu'il a été enlevé sur el trou de fixation clignotant du support principal, voir photo 24.
- Remonter la plaque métallique dans le caoutchouc, avec la plaque métallique la plus à l'extérieure et une vis comme cela était le cas à l'origine, voir photo 25.
- Utiliser les colliers de serrage fournis pour diriger les fils de feu de plaque et de clignotants sur le support via les 2 fentes, voir photo 26.

R&G Racing

Unit 1, Shelley's Lane, East Worldham, Alton, Hampshire, GU34 3AQ

Tel: +44 (0)1420 89007 Fax: +44 (0)1420 87301 www.rg-racing.com Email: info@rg-racing.com



- L'assemblage de support de plaque peut maintenant être monté sur la moto. Pour cela, réutiliser les 2 boulons M6 pour fixer les cotés de la queue de support de plaque dans les trous de fixation du cadre des 2 cotés, voir photo 27.
- Prendre le boulon M8 x 12mm (article 4) et insérez le dans le trou de fixation central de la queue de support de plaque puis serrer dans le trou fileté, voir photo 28.
- Pour connecter le nouveau feu au linceul principal, les fils doivent être « coupés puis fermé ». Pour cela, coupez le connecteur et une longueur de fil (voir photo 29) du feu d'origine puis appliquez des connecteurs sur ces 3 fils. Montez les connecteurs opposés sur le fil de feu puis connectez le fil comme suit : rouge d'origine au jaune / bleu d'origine au rouge / noir ou jaune d'origine au Noir.
- Reconnecter les 3 connecteurs au linceul principal sur la moto puis vérifier que tous les feux fonctionnent correctement (*Le 4^e connecteur (photo 30) n'est plus utile*).
- Le garde boue arrière peut maintenant être remonté sur la moto en vous servant des étapes contraire au processus de démontage.
- Remonter le garde boue, les rivets et les 2 boulons, voir photos 31, 32 & 33.
- Remonter les plaques métalliques des 2 cotés de la moto en utilisant les 2 boulons, voir photo 34.
- Remonter les 2 caches plastiques des 2 cotés de la moto, en utilisant les boulons d'origine, voir photo 35.
- Remonter les 2 caches plastiques des 2 cotés de la moto, en utilisant les boulons d'origine, voir photo 36.
- Remonter le siège pilote et le siège passager à l'aide des boulons d'origine.
- Veillez à ce que la queue de support soit correctement fixée et que tous les boulons soient complètement serrés.
- Remonter la plaque d'immatriculation (peut nécessiter un perçage).
- Selon la loi locale, attachez le réflecteur fourni à son emplacement approprié.
- Tester le feu de plaque et les feux avant de prendre la route.

ISSUE 1 08/10/2015 (AR)

Cette notice est disponible sur www.rg-racing.com