

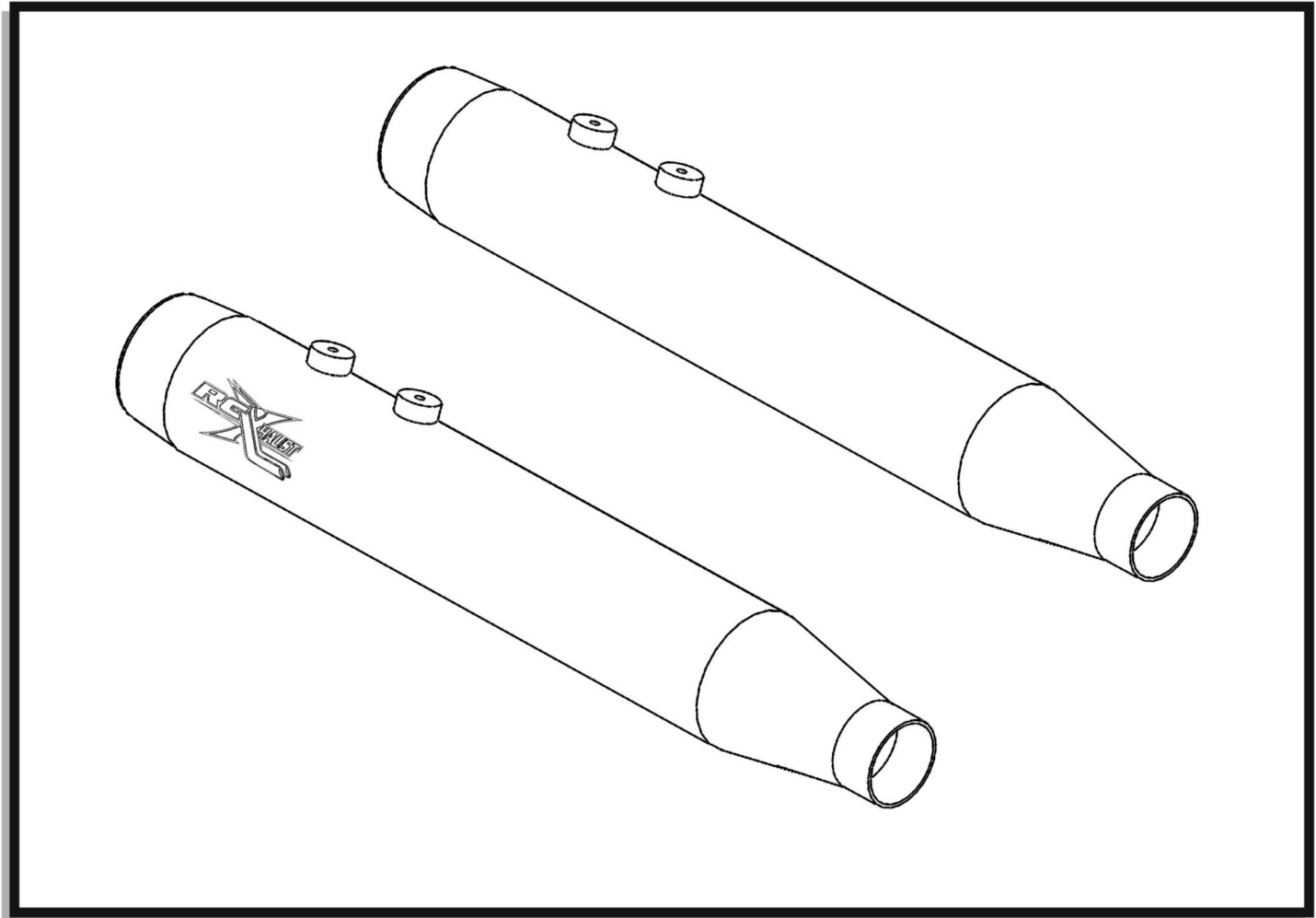

RCX 213C, 213B

3.0" SLIP-ON EXHAUST

07-12 FXST/FLST, 10-12 FLTSE, 08-13 FXCW/C
2013 FXSB
EXCLUDES: (FSXTD/FLSTSB/FLSTF/FLSTN)



PARTS INCLUDED

Ref.	Part Number	Description	Qty
1)	RCX-CAN213TC	Muffler Assembly, Top	1
2)	RCX-CAN213BC	Muffler Assembly, Bottom	1
3)	ZTIP	Exhaust Tip	2
4)	F04-20-04BHC	Screw, 1/4-20x1/2 BHCS CHROME	4

WARRANTY

RCX Exhaust products are warranted against defects in material and workmanship for a period of 90 days from the date of original purchase. This warranty is limited to the repair or replacement of a RCX Exhaust product proven to be defective from normal use. This warranty does not cover any RCX Exhaust product subject to abuse, misuse, improper installation or modification.



373 Mitch McConnell Way • Bowling Green, Kentucky 42101 • 1-800-360-0915

fax: 270-842-9527 • email: rcc@rccomponents.com

www.rccomponents.com



RCX 213C, 213B

3.0" SLIP-ON EXHAUST

07-12 FXST/FLST, 10-12 FLSTSE, 08-13 FXCW/C
2013 FXSB
EXCLUDES: (FSXTD/FLSTSB/FLSTF/FLSTN)

NOTE

RCX exhaust systems may not meet EPA and/or carb emissions in the State of California or other States with similar emission control restrictions. End user of product shall determine acceptable use in compliance with local and federal laws. User of product assumes all risk and financial obligations in violation of such regulations as a result of vehicle inspections or emission tests.

REMOVAL INSTRUCTIONS

1. Loosen the exhaust clamps holding the mufflers onto the head pipes.
2. Locate the muffler support bracket and remove the hex head bolts that secure the muffler to the bracket. *(These hex head bolts will be reused when installing the new mufflers)*
3. Carefully remove the mufflers by sliding them off each head pipe.
4. Remove the stock exhaust clamps from the front end of each muffler. *(These will be reused when installing the new mufflers.)*

INSTALLATION INSTRUCTIONS

1. Remove mufflers from packaging and place on a blanket or any non abrasive surface.
2. Slide on stock exhaust clamps onto the front end of each muffler. NOTE: Position the exhaust clamp so that you can get to the nut after installation.
3. Carefully slide mufflers onto the head pipes. NOTE: Muffler with RCX logo attaches to the rear cyl. head pipe.
4. Using the factory hex head bolts, attach the mufflers to the muffler support bracket. NOTE: Leave these bolts loose at this time.
5. Align the mufflers so they are parallel with one another.
6. Tighten the exhaust clamps that secure the mufflers to the head pipes.
7. Tighten the factory hex head bolts that secure the muffler to the support brackets.
8. Be sure to check and tighten all hardware before starting the motorcycle.

NOTE: When installing a new set of chrome mufflers, make sure your hands are clean and free of oil. After installation, thoroughly clean pipes with a soft cloth and cleaning solution (chrome wax/polish, glass cleaner, etc.) that will leave no residue before starting the motorcycle.

FUEL MANAGEMENT

RC Components is taking the guesswork out of tuning!

When you install a performance exhaust system, the air flow changes and can lead to an incorrect air/fuel ratio. So you need a fuel management system that will correct this ratio and keep your engine running smooth and efficient.

The **RCX-Celerator** is the best of the best in fuel management! It is a full closed loop system which is the same technology used by today's major auto and motorcycle manufacturers. No programming, No adjustments, No downloads. Just plug it in and ride, it is that easy! The RCX-Celerator automatically detects and adjusts for changes in load, RPM, temperature, elevation and engine modifications. So no matter where you travel your bike will always be running it's best. For more information visit www.rccomponents.com.

No Downloads • No DynoTuning • No Adjustments • Self tunes as you ride • Quicker throttle response



373 Mitch McConnell Way • Bowling Green, Kentucky 42101 • 1-800-360-0915

fax: 270-842-9527 • email: rcc@rccomponents.com

www.rccomponents.com