

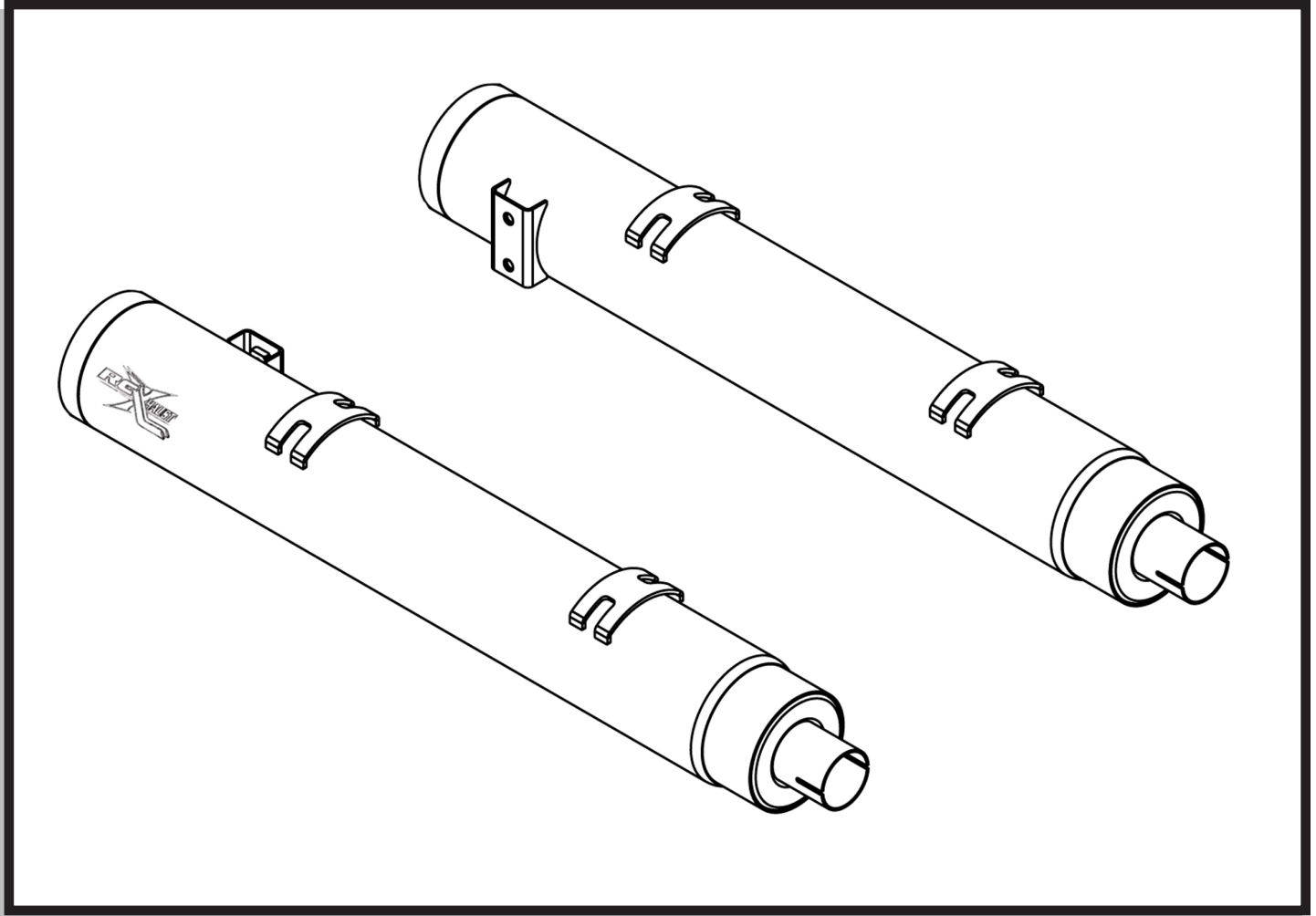

RCX111C, RCX111B

4.0" SLIP-ON EXHAUST

2010 - UP INDIAN CHIEFTAIN



PARTS INCLUDED

Ref.	Part Number	Description	Qty
1)	RCXCAN-111R	Muffler Assembly, Right	1
2)	RCXCAN-111R	Muffler Assembly, Left	1
3)	F04-20-04BHC	Screw, 1/4-20x1/2"BHC	4



373 Mitch McConnell Way • Bowling Green, Kentucky 42101
1-800-360-0915 • fax: 270-842-9527 • email: rcc@rcccomponents.com
www.rcccomponents.com

RCX111C, RCX111B

4.0" SLIP-ON EXHAUST

2010-UP INDIAN CHIEFTAIN

NOTE

RCX exhaust systems may not meet EPA and/or carb emissions in the State of California or other States with similar emission control restrictions. End user of product shall determine acceptable use in compliance with local and federal laws. User of product assumes all risk and financial obligations in violation of such regulations as a result of vehicle inspections or emission tests.

INSTALLATION INSTRUCTIONS

- 1) Make sure the motorcycle is cool and place securely on a service lift or center stand.
- 2) Remove right & left side saddlebag by using quick release handles inside saddlebags.
Note: If bike is equipped with Auto Lock saddlebags remove the right side cover under the seat to access and unplug the Auto Lock connection.
- 3) Loosen both muffler band clamps and hose clamp on the front of each muffler.
- 4) Using a 13mm wrench, remove the two M8x1.25mm bolts that secure each muffler to the bike.
Note: Radio antenna must be removed to access right side muffler bolts.
- 5) Carefully slide each muffler off head pipes.
- 6) Install the factory band clamps over the front of each RCX muffler with nut facing downward.
- 7) Slip each RCX muffler over the stock head pipes with RCX logo facing outward.
- 8) Attach RCX mufflers to the support brackets using the factory M8x1.25mm bolts that were removed in step (4).
- 9) Tighten the two exhaust band clamps on the front of each muffler. (Torque 40-45 ft/lbs)
- 10) Reattach antenna and saddlebags. Reconnect Auto Lock connector if equipped.
- 11) Inspect all hardware for tightness and start motorcycle. **(See Care & Maintenance below)**
- 12) After first initial ride, allow mufflers to cool and re-torque muffler band clamps.

Exhaust Care & Maintenance

After installation thoroughly clean RCX mufflers with a soft cloth to remove any oil, dirt or fingerprints with a solvent that leaves no residue (chrome polish, glass cleaner, alcohol, etc) before starting. Discoloration is possible due to overheating if bike is left at idle for a long period of time and if intake leaks are present.



373 Mitch McConnell Way • Bowling Green, Kentucky 42101
1-800-360-0915 • fax: 270-842-9527 • email: rcc@rccomponents.com
www.rccomponents.com