

INSTALLATION INSTRUCTIONS

Horizon® Installation Instructions
Indian Scout

P/N: HZ15100

***IMPORTANT:
PLEASE GIVE CUSTOMER ENCLOSED INFORMATION!***



Thank you for your HeliBars® purchase.

HeliBars are designed to increase your long distance comfort and improve the handling of your motorcycle, and we feel confident you will enjoy them. The Horizon is the most technologically advanced handlebar system to ever grace a motorcycle. Many safety features have been included in the design. It is of the utmost importance the bars are installed by a mechanic with good mechanical skills following the installation instructions provided.

HeliBars INSTALLATION

**IMPROPER INSTALLATION COULD RESULT IN SERIOUS INJURY OR DEATH.
HAVE A QUALIFIED MECHANIC INSTALL YOUR HeliBars.**

**!! CAUTION !! MAKE SURE THE HeliBars ARE FULLY SEATED. TIGHTEN BAR
END DAMPER WEIGHTS FIRMLY. AFTER INSTALLATION, MOVE BARS LOCK
TO LOCK AND CHECK CLEARANCE OF: 1.CABLES 2. HYDRAULIC LINES
3.WIRES 4.FAIRING 5.FUEL TANK. TORQUE ALL HARDWARE TO MANUFAC-
TURER'S SPECIFICATIONS.**

IF YOU HAVE INSTALLATION QUESTIONS, PLEASE CALL 1-800-859-4642.

**HELI MODIFIED, INC. ASSUMES NO LIABILITY FOR ANY INJURY OR LOSS OF
PROPERTY WHICH MAY RESULT FROM IMPROPER INSTALLATION OR USE OF
ANY HeliBars.**



WARRANTY / RETURN POLICY

We make every effort to build a quality product so you can fully enjoy your riding experience. Thank you for your order.

HeliBars® may be returned for defects in materials and workmanship within one year from the date of shipment to the original purchaser, in which event the purchaser may receive a replacement set of HeliBars.

If within thirty (30) days of the shipping date you are not satisfied for any reason, you can return the HeliBars. Return policy is valid for original purchaser only. If HeliBars are purchased from a vendor other than Heli Modified, Inc., customer must contact vendor where purchased regarding returns. Refund will be extended to original purchaser only. There are no other warranties which extend beyond this.

Conditions of this 30 day return policy:

- 1. Bars must not be used as a tie down point. (See attached ‘Trailer Instructions’).**
- 2. Bars cannot be damaged, dented, or altered in any way.**
- 3. Bars cannot be overtorqued.**
- 4. Refund will be for product purchase price only, and credited to original purchaser only.**
- 5. Product must be returned with all original equipment, documents and in original packaging. There must be no physical damage caused by the customer or by carrier.**
- 6. A Return Authorization Number must be obtained from us before you return the product.**

We reserve the right to charge a re-stocking fee of up to 25% if the above criteria are not met.

THERE ARE NO FURTHER EXPRESS OR IMPLIED WARRANTIES INCLUDING, BUT NOT LIMITED TO, IMPLIED WARRANTIES OF MERCHANTABILITY OR FITNESS FOR A PARTICULAR PURPOSE. By accepting this product, the consumer agrees to arbitrate and litigate any controversy in the State of Maine, and under the laws of the State of Maine.

HELI MODIFIED INC. ASSUMES NO LIABILITY FOR ANY INJURY OR LOSS OF PROPERTY WHICH RESULT FROM IMPROPER INSTALLATION OR USE OF ANY HELI BARS. ALL HELI MODIFIED, INC. PRODUCTS SHOULD BE INSTALLED BY A QUALIFIED MECHANIC. IMPROPER INSTALLATION MAY CAUSE DEATH OR INJURY.

Ride Safe and Enjoy!





Horizon Installation Instructions Indian Scout

Part # HZ15100

Height: +2.5 up to 4.5 inches ~ Set Back: Up to 4 inches ~ Width: 27.5" to 29.5"

Cover the fuel tank area prior to disassembly.

Before the stock handlebars and all controls are dis-assembled:

Loosen the banjo bolt at the bottom of the front brake master cylinder and rotate the hydraulic line banjo fitting so it points straight forward, then retighten banjo bolt. It will not be necessary to bleed the front brakes. Remove cable ties holding wire looms to stock bar.

- 1.) Remove the left control housing and clutch lever mount from the left bar. Remove the left grip with air pressure, or slide a long shaft spade screw driver down between the grip and the handlebar tube and drop some rubbing alcohol down under the grip. Remove screw driver, twist grip and remove.
- 2.) Remove front brake master cylinder from right handlebar tube. Loosen throttle housing screw enough to dislodge the dowel pin in the front half of the housing. Loosen and remove the handlebar mounting clamp, slide throttle assembly off end of stock handlebar and rest throttle assembly on side of bike with a shop rag around it.
- 3.) Mount the Rebel lower assembly into the fork mounting clamp, install cover and lightly tighten. Adjust bar left or right to show equal amounts of knurling to center the bar in the mount. Rotate bar back at about a 45 degree angle. This is a good starting point. Torque handlebar mounting clamps to 16-18 ft. lbs.
- 4.) Remove safety cap and hardware from right handlebar pivot shaft (see drawing on page 8) and slide throttle assembly over handlebar tube. Install pivot shaft into upper clamp and fully seat it, re-install safety cap and hardware and torque to 7 ft. lbs. Engage the throttle assembly dowel pin into the locating hole and tighten throttle assembly.

- 5.) Install the front brake master cylinder and tighten.
- 6.) Install left side control housing onto left handlebar and mount it to it's upper pivot. Install safety cap and hardware and torque to 7 ft lbs. as described for the right side. Install clutch lever mount.
- 7.) Adjust bars as described by the illustration. When adjusted to your personal preference, torque all pivots as described. Use 2 cable ties per side to attach wire looms to handlebar risers.

**!! CAUTION!! BARS MUST BE TORQUED TO
SPECIFIED VALUES.
THEY MUST NOT BE OVER TORQUED.
OVERTIGHTENED HARDWARE CAN LOSE INTEGRITY.**

For questions regarding installation please call 1-800-859-4642.

**HELI MODIFIED, INC ASSUMES NO LIABILITY FOR ANY INJURY OR LOSS OF
PROPERTY WHICH MAY RESULT FROM IMPROPER INSTALLATION OR USE OF
ANY HELIBARS.**





Photo # 2



Photo # 1





Photo # 3



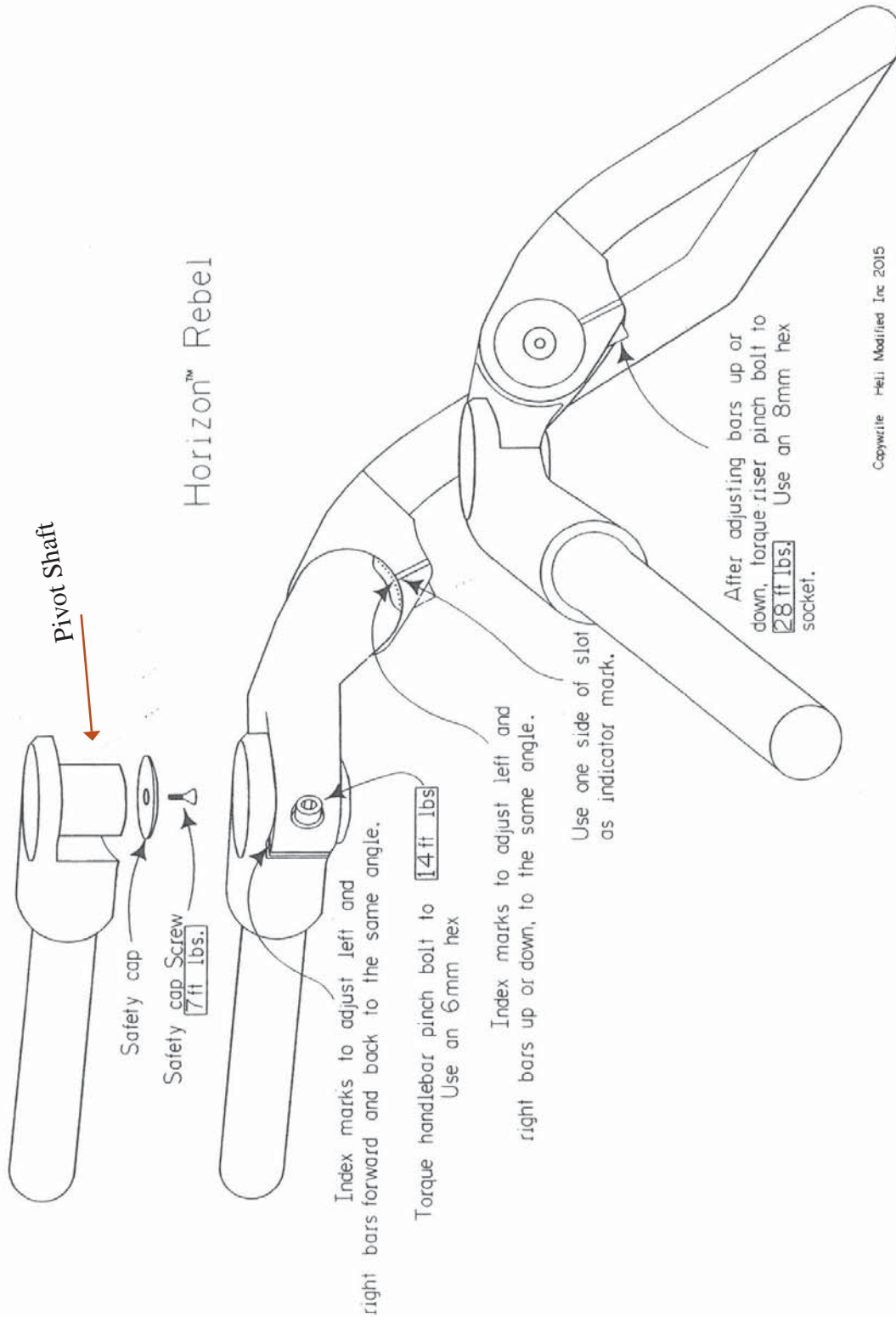

Copyright Heli Modified Inc 2015



IMPORTANT INFORMATION ABOUT POWDER COATED HELIBARS

HeliBars® are finished with a polyester powder coating. The polyester is recommended for outdoor use because of its excellent UV resistant quality; if we were to use an epoxy it would tend to fade and chalk pretty quickly when exposed to sunlight and UV rays.

Care must be taken during installation because the finish can be scratched by the sharp surfaces of the controls and master cylinder clamps. When mounting the master cylinders to bars, do not let them move around the bars with the caps loose. Mount them in the proper position and hand tighten the screws until final adjustments are made; in this way you will lessen the possibility of scratching.

NOTE: Powder coat finish is not indestructible, there are chemicals which may react negatively when applied to finish. Brake fluid may cause deterioration of the finish. We do not recommend the use of acetone or similar chemicals for cleaning purposes. We would recommend the use of an over-the-counter adhesive remover (such as Goo Gone) for the removal of any extraneous material. Please read labels directions for any cleaning/polishing product before use. If you have any questions regarding the use of any over-counter-products with the HeliBars, please call us before applying them to the powder coated finish.

If care is taken during installation, your HeliBars will continue to look as good as when they were new. They will look great for years to come with a bit of wax and careful cleaning. Thank you for your purchase, ride safe and enjoy!

Sincerely,

Harry Eddy, President



Trailing with HeliBars®

HeliBars clip ons and handlebars must not be used as the primary holding points for tie downs while trailering. *As with your stock bars* applying extreme force to the ends of the bars can bend the bars or rotate them on their mounts.

Use a wheel chock and pull the machine down and forward using soft ties or similar, attached to the lower triple clamp.

Bars should only be used as secondary attachment points to steady the motorcycle from lateral sway.

Failure to follow these guidelines can cause damage to the bars and the motorcycle, and may also void our warranty.

